



P-DUKE POWER

WAF300W Series

DC-DC Converter
Up to 300 Watts

3
YEARS
WARRANTY

ROHS
COMPLIANT

REACH
COMPLIANT

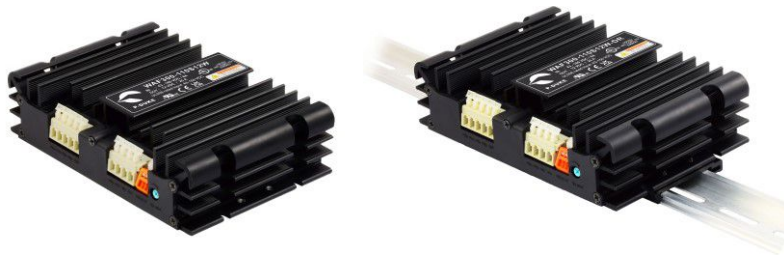

Railway



Automation



Datacom



IPC



Industry



Measurement



Telecom



Charger



Automobile



Boat



Medical



PV



3000 VAC
Isolation Voltage

4 : 1
Wide Input Range

ADJ.
Output Voltage

Constant
Current

Constant
Voltage

CURRENT SHARE

Internal
EN55032
Class **A**
Filter

NO
Min. Load
Required

REMOTE ON OFF

OCP

OTP

OVP

SCP

UVP

PART NUMBER STRUCTURE

WAF300 -	48	S	12	W	-	N	S	DR
Series Name	Input Voltage (VDC)	Output Quantity	Output Voltage (VDC)	Input Range		Remote Control Options	Load Share Options	Assembly Options
	48:18~75 110:43~160	S:Single	12:12 15:15 24:24 28:28 48:48	4:1		<input type="checkbox"/> :Positive logic, <input type="checkbox"/> :Negative logic	<input type="checkbox"/> : None <input type="checkbox"/> : Load Share	<input type="checkbox"/> : Wall mounted <input type="checkbox"/> : Din rail type

TECHNICAL SPECIFICATION All specifications are typical at nominal input, full load and 25°C unless otherwise noted

Model Number	Input Range	Output Voltage	Output Current @ Full Load	Input Current @ No Load	Efficiency
	VDC	VDC	A	mA	%
WAF300-48S12W	18 ~ 75	12	25	30	89
WAF300-48S15W	18 ~ 75	15	20	30	90
WAF300-48S24W	18 ~ 75	24	12.5	30	92
WAF300-48S28W	18 ~ 75	28	10.8	30	91
WAF300-48S48W	18 ~ 75	48	6.3	30	92
WAF300-110S12W	43 ~ 160	12	25	20	89
WAF300-110S15W	43 ~ 160	15	20	20	90
WAF300-110S24W	43 ~ 160	24	12.5	20	91
WAF300-110S28W	43 ~ 160	28	10.8	20	91
WAF300-110S48W	43 ~ 160	48	6.3	20	92

INPUT SPECIFICATIONS						
Parameter	Conditions		Min.	Typ.	Max.	Unit
Operating input voltage range	48Vin(nom) 110Vin(nom)		18 43	48 110	75 160	VDC
Start up voltage	48Vin(nom) 110Vin(nom)		18 43			VDC
Shutdown voltage	48Vin(nom) 110Vin(nom)		15.6 33.0	16.2 34.5	16.8 36.0	VDC
Start up time	Constant resistive load	Power up Remote ON/OFF	140			ms
Input surge voltage	1 second, max.	48Vin(nom) 110Vin(nom)	100 185			VDC
Input filter	Common choke + Pi type					
Remote ON/OFF	Referred to -Vin	Positive logic DC-DC ON (Standard) DC-DC OFF Negative logic DC-DC ON (Option) DC-DC OFF Input current of Ctrl Remote off input current	-0.5	4.0	1	mA mA
					Open or 3 ~ 12 VDC Short or 0 ~ 1.2 VDC Short or 0 ~ 1.2 VDC Open or 3 ~ 12 VDC	

OUTPUT SPECIFICATIONS						
Parameter	Conditions	Min.	Typ.	Max.	Unit	
Rated Output Power	Normal Vout and Iout		300		W	
Voltage accuracy		-1		+1	%	
Line regulation	Low Line to High Line at Full Load	-0.2		+0.2	%	
Load regulation	No Load to Full Load	-0.5		+0.5	%	
Voltage adjustability	Maximum output deviation is inclusive of remote sense	-20		+20	%	
Remote sense	% of Vout(nom) If remote sense is not being used, Sense terminals should be connected to corresponding polarity Vout terminals.			10	%	
Ripple and noise	Measured by 20MHz bandwidth 12Vout, 15Vout 24Vout, 28Vout 48Vout		100 200 300	125 250 350	mVp-p	
Temperature coefficient		-0.02		+0.02	%/°C	
Transient response recovery time	25% load step change		250		µs	
Over voltage protection	% of Vout(nom); Latch mode	125		140	%	
Over load protection	% of Iout rated; C.C. mode * "C.C. Mode" is "Constant Current Mode" and test by nominal input.	105		115	%	
Short circuit protection		C.C. mode, automatic recovery				
Load Share accuracy	Full Load *Connect the LS (Terminal 11) from each converter. The converter can parallel to increase output current. It has internal load share function in this converter. (This function is only for suffix "-S" part.)	-10		+10	%	

GENERAL SPECIFICATIONS						
Parameter	Conditions	Min.	Typ.	Max.	Unit	
Isolation voltage	1 minute Input to Output Input (Output) to Case	3000 2100			VAC	
Isolation resistance	500VDC	1			GΩ	
Isolation capacitance			14000		pF	
Switching frequency	48VDC input 110VDC input	203 180	225 200	248 220	kHz	
Safety approvals	IEC/ EN/ UL62368-1 UL508				UL:E193009 UL:E468443 CB:UL(Demko)	
Standard approvals	EN50155 EN45545-2					
Case material					Aluminum	
Potting material					Silicone (UL94 V-0)	
Weight					900g (31.74oz.)	
MTBF	MIL-HDBK-217F, Full load				1.490x 10 ⁵ hrs	

ENVIRONMENTAL SPECIFICATIONS						
Parameter	Conditions	Min.	Typ.	Max.	Unit	
Operating case temperature		-40		+100	°C	
Maximum case temperature				100	°C	
Over temperature protection			105		°C	
Storage temperature range		-40		+105	°C	
Thermal impedance	Mounted on the iron base-plate * The iron base-plate dimension is 19" X 5.25" X 0.063" (The height is EIA standard 3U).		1.1		°C/W	
Thermal shock					MIL-STD-810F	
Shock					EN61373, MIL-STD-810F	
Vibration					EN61373, MIL-STD-810F	
Relative humidity					5% to 95% RH	

EMC SPECIFICATIONS

Parameter	Conditions	Level
EMI	EN55032, EN50121-3-2 Without external component	Radiation Class A Conduction
EMS	EN55035, EN50121-3-2	
ESD	EN61000-4-2 Air $\pm 8kV$ and Contact $\pm 6kV$	Perf. Criteria A
Radiated immunity	EN61000-4-3 20V/m	Perf. Criteria A
Fast transient	EN61000-4-4 $\pm 2kV$	Perf. Criteria A
Surge	EN61000-4-5 EN55035 $\pm 1kV$ and EN50121-3-2 $\pm 2kV$	Perf. Criteria A
Conducted immunity	EN61000-4-6 10Vr.m.s	Perf. Criteria A
Power frequency magnetic field	EN61000-4-8 100A/m continuous; 1000A/m 1 second	Perf. Criteria A

CAUTION: This power module is not internally fused. An input line fuse must always be used.

CHARACTERISTIC CURVE

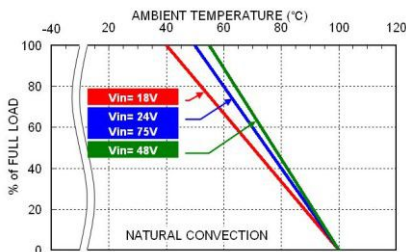

WAF300-48S Derating Curve

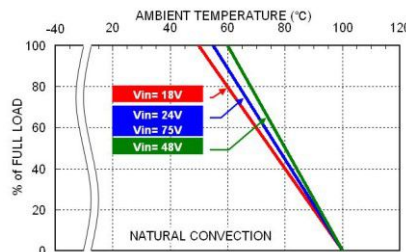

WAF300-48S With 3U Iron Base-Plate Derating Curve

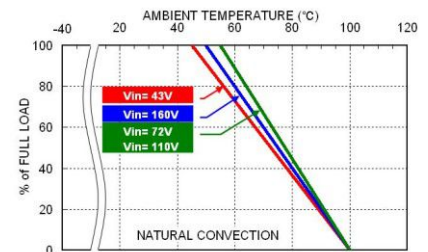

WAF300-110S Derating Curve

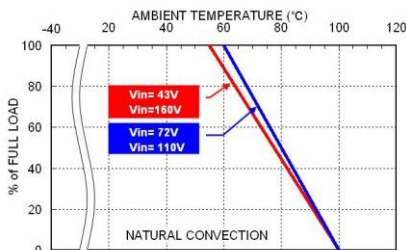

WAF300-110S With 3U Iron Base-Plate Derating Curve

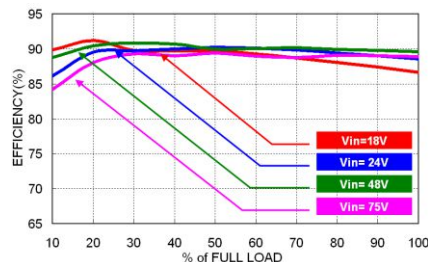

WAF300-48S12W Efficiency vs. Output Load

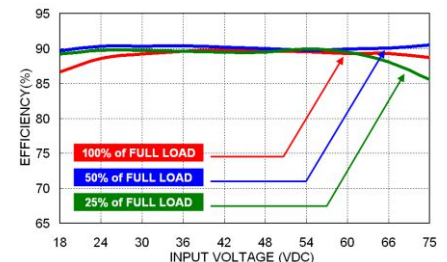

WAF300-48S12W Efficiency vs. Input Voltage

FUSE CONSIDERATION

This power module is not internally fused. An input line fuse must always be used.

This encapsulated power module can be used in a wide variety of applications, ranging from simple stand-alone operation to an integrated part of sophisticated power architecture.

To maximum flexibility, internal fusing is not included; however, to achieve maximum safety and system protection, always use an input line fuse.

The input line fuse suggest as below :

Model	Fuse Rating (A)	Fuse Type
WAF300-48S	25	Fast-Acting
WAF300-110S	12	Fast-Acting

The table based on the information provided in this data sheet on inrush energy and maximum DC input current at low Vin.

MECHANICAL DRAWING

WALL MOUNTED TYPE

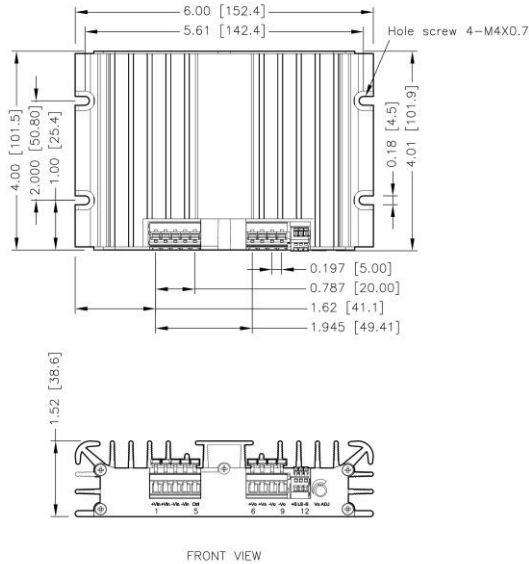

TERMINAL CONNECTION

Terminal	Define	Recommend Matching Wire
1, 2	+Vin	12-16 AWG
3, 4	-Vin	12-16 AWG
5	Ctrl	12-28AWG
6, 7	+ Vout	12-16 AWG
8, 9	- Vout	12-16 AWG
10	+ Sense	20-28 AWG
11	LS (option)	20-28 AWG
12	- Sense	20-28 AWG

- * The current rating of the terminal block is 15 amps/pole.
- * Using 2 poles at the same time when operating is recommended if the total current are more than 15 amps or choose optional 2-way splitter. (Please refer to the diagram below)
- * Input voltage vs. Input terminal, refer to the table below.

Output power	Input voltage	Input terminal
300W; Full load	$\geq 23V$	1 pole
	$< 23V$	2 poles
400W; C.C. mode	$\geq 32V$	1 pole
	$< 32V$	2 poles

1. All dimensions in inch [mm]
2. Tolerance : $x.xx \pm 0.02$ [$x.x \pm 0.5$]
 $x.xxx \pm 0.010$ [$x.xx \pm 0.25$]
3. The screw locked torque: MAX 14kgf-cm/1.37N.m

DIN RAIL TYPE

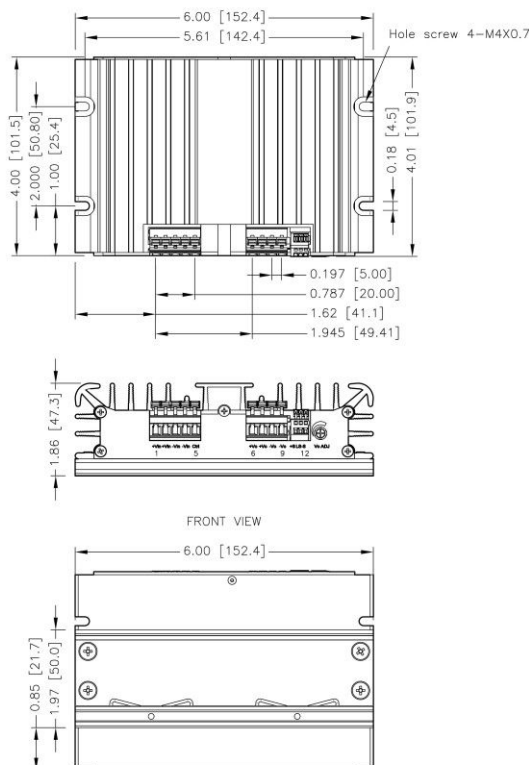

2-WAY SPLITTER (OPTIONAL ACCESSORY)

The 2-way splitter can be used for transforming a thick wire into 2 thin wires to the terminal block.
The 2-way splitter P/N:5J-C0045-F.

2-WAY SPLITTER Mechanical Drawing

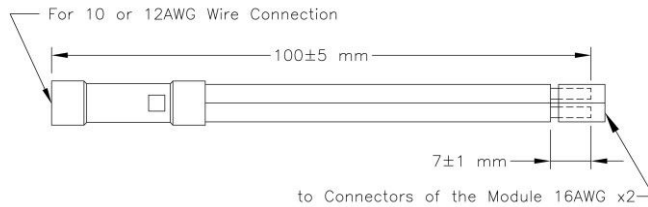

Connection Configuration

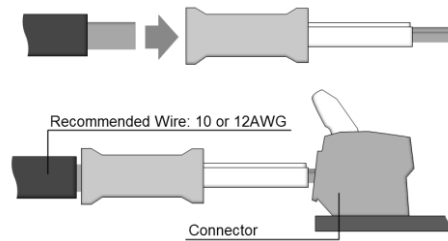

THERMAL CONSIDERATIONS

The power module operates in a variety of thermal environments. However, sufficient cooling should be provided to help ensure reliable operation of the unit. Heat is removed by conduction, convection, and radiation to the surrounding environment. Proper cooling can be verified by measuring the point as the figure below. The temperature at this location should not exceed "Maximum case temperature". When operating, adequate cooling must be provided to maintain the test point temperature at or below "Maximum case temperature". You can limit this temperature to a lower value for extremely high reliability.

