



# P-DUKE POWER

## QAE60U Series

QUARTER-BRICK DC-DC Converter  
Up to 60 Watts

**3**  
YEARS  
WARRANTY

ROHS  
COMPLIANT

REACH  
COMPLIANT



Railway



Automation



Datacom



IPC



Industry



Measurement



Telecom



Automobile



Boat



Charger



Medical



PV

UL US CB CE UK CA

**3000**  
VAC  
Reinforced  
Insulation

**2250**  
VDC  
Basic  
Insulation

**12:1**  
Ultra-Wide  
Input  
Range

**HOLD**  
**UP**

**NO**  
Min. Load  
Required

**LOW**  
Standby  
Power

**REMOTE**  
**ON**  
**OFF**

**OCP**

**OTP**

**OVP**

**SCP**

**UVP**

### PART NUMBER STRUCTURE

QAE60	-	72	S	05	U	-	K	P	HS
Series Name		Input Voltage (VDC)	Output Quantity	Output Voltage (VDC)	Input Range		Bus & UVP adj. Options	Remote Control Options	Assembly Options
		36: 9~75 72: 14~160	S: Single	05:5 12:12 15:15 24:24 28:28 48:48 53:53	8:1 12:1		□: None K: With Bus & UVP adj. V: With UVP adj.	□: Negative logic P: Positive logic	□: None <b>Heat-sink type</b> HS:7G-0029B-F;H=0.24" HS1:7G-0030B-F;H=0.5" HS2:7G-0031B-F;H=0.24" HS3:7G-0032B-F;H=0.5" HS4:7GA0124P01-F;H=0.65" HS5:7GA0125P01-F;H=1" <b>Through hole type</b> TH:No thread*

\* The module can't equip. Heat-sink with TH option

**TECHNICAL SPECIFICATION** All specifications are typical at nominal input, full load and 25°C unless otherwise noted

Model Number	Input Range	Output Voltage	Output Current @Full Load	Input Current @No Load	Efficiency	Maximum Capacitor Load
	VDC	VDC	A	mA	%	μF
QAE60-36S05U	9 ~ 75	5	12	20	89	24000
QAE60-36S12U	9 ~ 75	12	5	30	89	4200
QAE60-36S15U	9 ~ 75	15	4	30	90	2700
QAE60-36S24U	9 ~ 75	24	2.5	20	90	1100
QAE60-36S28U	9 ~ 75	28	2.15	20	90	780
QAE60-36S48U	9 ~ 75	48	1.25	20	91	260
QAE60-36S53U	9 ~ 75	53	1.14	20	91	220
QAE60-72S05U	14 ~ 160	5	12	15	89	24000
QAE60-72S12U	14 ~ 160	12	5	20	89	4200
QAE60-72S15U	14 ~ 160	15	4	20	89	2700
QAE60-72S24U	14 ~ 160	24	2.5	15	90	1100
QAE60-72S28U	14 ~ 160	28	2.15	15	90	780
QAE60-72S48U	14 ~ 160	48	1.25	15	90	260
QAE60-72S53U	14 ~ 160	53	1.14	15	90	220

**INPUT SPECIFICATIONS**

Parameter	Conditions		Min.	Typ.	Max.	Unit	
Operating input voltage range	36Vin(nom)		9	36	75	VDC	
	72Vin(nom)		14	72	160		
Start up voltage	36Vin(nom)					9	VDC
	72Vin(nom)					14	
Shutdown voltage	36Vin(nom)		7.3	7.7	8.1	VDC	
	72Vin(nom)		10	11	12		
Start up time	Constant resistive load	Power up				75	ms
		Remote ON/OFF				75	
Input Transient voltage	100 mS, max.	36Vin(nom)	8.1				VDC
		72Vin(nom)	12				
Input surge voltage	1 second, max.	36Vin(nom)				100	VDC
		72Vin(nom)				185	
Input filter <sup>(1)</sup>			Pi type				
Remote ON/OFF	Referred to -Vin pin	Negative logic	DC-DC ON	Short or 0 ~ 1.2VDC			mA
		(Standard)	DC-DC OFF	Open or 3 ~ 12VDC			
		Positive logic	DC-DC ON	Open or 3 ~ 12VDC			
		(Option)	DC-DC OFF	Short or 0 ~ 1.2VDC			
		Input current of Ctrl pin	-0.5			1	mA
		Remote off input current				3	mA

**OUTPUT SPECIFICATIONS**

Parameter	Conditions	Min.	Typ.	Max.	Unit
Voltage accuracy		-1.0		+1.0	%
Line regulation	Low Line to High Line at Full Load	-0.1		+0.1	%
Load regulation	No Load to Full Load	-0.1		+0.1	%
Voltage adjustability	Maximum output deviation is inclusive of remote sense	-20		+10	%
Remote sense	% of Vout(nom). If remote sense is not being used, SENSE pins should be connected to corresponding polarity OUTPUT pins.			10	%
Ripple and noise	Measured by 20MHz bandwidth With a 1 $\mu$ F/25V X7R MLCC and a 22 $\mu$ F/25V POS-CAP 5Vout With a 22 $\mu$ F/25V X7R MLCC 12Vout, 15Vout With a 4.7 $\mu$ F/50V X7R MLCC 24Vout, 28Vout With a 2.2 $\mu$ F/100V X7R MLCC 48Vout, 53Vout		75 100 200 300		mVp-p
Temperature coefficient		-0.02		+0.02	%/°C
Transient response recovery time	25% load step change		250		$\mu$ s
Over voltage protection	% of Vout(nom); Hiccup mode	120		135	%
Over load protection	% of Iout rated; Hiccup mode	120		140	%
Short circuit protection		Continuous, automatic recovery			

**GENERAL SPECIFICATIONS**

Parameter	Conditions	Min.	Typ.	Max.	Unit
Isolation voltage	1 minute	72Vin(nom)	Input to Output	3000	VAC
	(Reinforced insulation)		Input (Output) to Base-Plate	1500	
	1 minute	36Vin(nom)	Input to Output	2250	VDC
	(Basic insulation)		Input (Output) to Base-Plate	1600	
Isolation resistance	500VDC			1	G $\Omega$
Isolation capacitance				1000	pF
Switching frequency		160	180	200	kHz
Safety approvals	IEC/ EN/ UL62368-1			UL:E193009 CB:UL(Demko)	
Standard approvals	EN50155 EN45545-2				
Case material		Aluminum base-plate with plastic case			
Potting material		Silicone (UL94 V-0)			
Weight		64g (2.26oz)			
MTBF	MIL-HDBK-217F, Full load	7.381 x 10 <sup>5</sup> hrs			

**ENVIRONMENTAL SPECIFICATIONS**

Parameter	Conditions	Min.	Typ.	Max.	Unit
Operating base-plate temperature	With derating	-40		+105	°C
Maximum case temperature				105	°C
Over temperature protection			110		°C
Storage temperature range		-55		+125	°C
Thermal impedance	Module without assembly option		8.3		°C/W
	Only mount on the iron base-plate		2.5		
	Heat-sink type with 0.24" Height		7.4		
	Heat-sink type with 0.5" Height		6.2		
	Heat-sink type with 0.65" Height		4.9		
	Heat-sink type with 1" Height		4.0		
Thermal shock		MIL-STD-810F			
Shock		EN61373, MIL-STD-810F			
Vibration		EN61373, MIL-STD-810F			
Relative humidity		5% to 95% RH			

EMC SPECIFICATIONS			
Parameter	Conditions	Level	
EMI	EN55032, EN50121-3-2	With external components	Class A, Class B
EMS	EN55035, EN50121-3-2		
ESD	EN61000-4-2	Air $\pm$ 8kV and Contact $\pm$ 6kV	Perf. Criteria A
Radiated immunity	EN61000-4-3	20 V/m	Perf. Criteria A
Fast transient	EN61000-4-4	$\pm$ 2kV	Perf. Criteria A
	QAE60-36S□□U	With 2 pcs of aluminum electrolytic capacitor (Nippon Chemi-con KY series, 220 $\mu$ F/100V)	
	QAE60-72S□□U	With 2 pcs of aluminum electrolytic capacitor (Nippon Chemi-con KXJ series, 150 $\mu$ F/200V)	
Surge	EN61000-4-5	EN55035: $\pm$ 1kV and EN50121-3-2: $\pm$ 2kV	Perf. Criteria A
	QAE60-36S□□U	With 2 pcs of aluminum electrolytic capacitor (Nippon Chemi-con KY series, 220 $\mu$ F/100V)	
	QAE60-72S□□U	With 2 pcs of aluminum electrolytic capacitor (Nippon Chemi-con KXJ series, 150 $\mu$ F/200V)	
Conducted immunity	EN61000-4-6	10 Vr.m.s	Perf. Criteria A
Power frequency magnetic field	EN61000-4-8	100A/m continuous; 1000A/m 1 second	Perf. Criteria A

**Note:**

- Input source impedance: The power module will operate as specifications without external components, assuming that the source voltage has a very low impedance and reasonable input voltage regulation. Highly inductive source impedances can affect the stability of the power module. Since real-world voltage source has finite impedance, performance can be improved by adding external filter capacitor.  
The QAE60-36S□□U recommended Nippon Chemi-con KY series, 220 $\mu$ F/100V.  
The QAE60-72S□□U recommended Nippon Chemi-con KXJ series, 150 $\mu$ F/200V.
- BASE-PLATE GROUNDING: When connect two screw bolts to shield plane, the EMI could be reduced.

**CAUTION:** This power module is not internally fused. An input line fuse must always be used.

**CHARACTERISTIC CURVE**

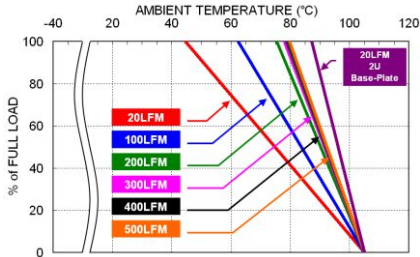

QAE60-72S05U Derating Curve  
(See Thermal Considerations)

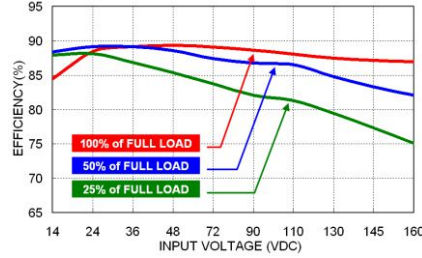

QAE60-72S05U Efficiency vs. Input Voltage

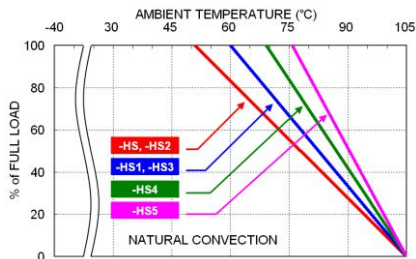

QAE60-72S05U Derating Curve with Heat-sink  
(See Thermal Considerations)

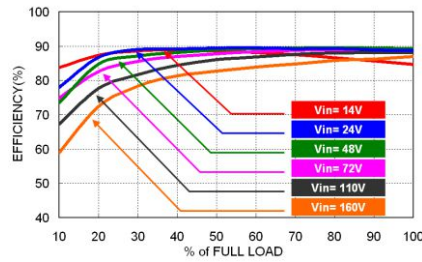

QAE60-72S05U Efficiency vs. Output Load

**FUSE CONSIDERATION**

This power module is not internally fused. An input line fuse must always be used.

This encapsulated power module can be used in a wide variety of applications, ranging from simple stand-alone operation to an integrated part of sophisticated power architecture.

To maximum flexibility, internal fusing is not included; however, to achieve maximum safety and system protection, always use an input line fuse.

The input line fuse suggest as below :

Model	Fuse Rating (A)	Fuse Type
QAE60-36S□□U	12	Fast-Acting
QAE60-72S□□U	8	Fast-Acting

The table based on the information provided in this data sheet on inrush energy and maximum DC input current at low Vin.

## MECHANICAL DRAWING

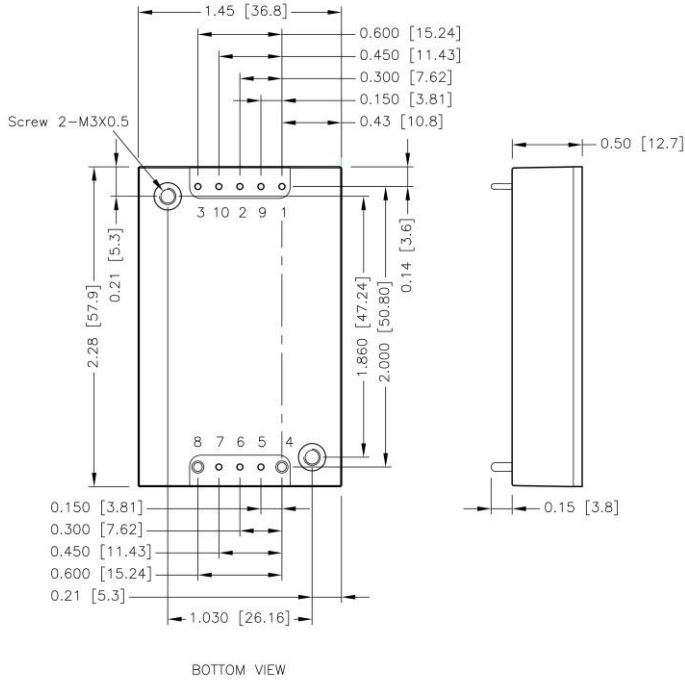

### PIN CONNECTION

PIN	DEFINE	DIAMETER
1	- Vin	0.04 Inch
2	Ctrl	0.04 Inch
3	+ Vin	0.04 Inch
4	- Vout	0.06 Inch
5	- Sense	0.04 Inch
6	Trim	0.04 Inch
7	+ Sense	0.04 Inch
8	+ Vout	0.06 Inch
9	Bus	0.04 Inch
10	UVLO	0.04 Inch

- All dimensions in inch [mm]
- Tolerance :x.xx±0.02 [x.x±0.5]  
x.xxx±0.010 [x.xx±0.25]
- Pin dimension tolerance ±0.004[0.10]
- The screw locked torque: MAX 3.5kgf-cm [0.34N-m]

## RECOMMENDED PAD LAYOUT

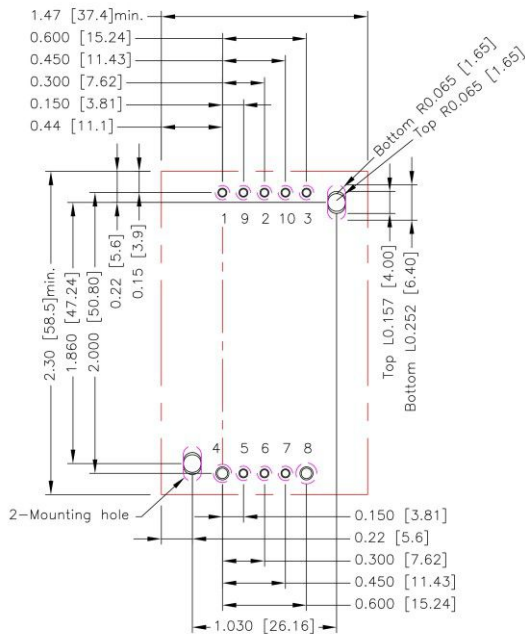

- All dimensions in inch[mm]
- Pad size(lead free recommended)
- Through hole 1.2.3.5.6.7.9.10:∅0.051[1.30]
- Through hole 4.8:∅0.075[1.90]
- Through hole of mounting:∅0.126[3.20]
- Top view pad 1.2.3.5.6.7.9.10:∅0.064[1.63]
- Top view pad 4.8:∅0.094[2.38]
- Top view pad of mounting:Groove R0.065[1.65]L0.157[4.00]
- Bottom view pad 1.2.3.5.6.7.9.10:∅0.102[2.60]
- Bottom view pad 8:∅0.150[3.80]
- Bottom view pad 4:∅0.130[3.30]
- Bottom view pad of mounting:Groove R0.065[1.65]L0.252[6.40]

## THERMAL CONSIDERATIONS

The power module operates in a variety of thermal environments.

However, sufficient cooling should be provided to help ensure reliable operation of the unit.

Heat is removed by conduction, convection, and radiation to the surrounding environment.

Proper cooling can be verified by measuring the point as the figure below.

The temperature at this location should not exceed "Maximum case temperature".

When operating, adequate cooling must be provided to maintain the test point temperature at or below "Maximum case temperature".

You can limit this temperature to a lower value for extremely high reliability.

- Thermal test condition with vertical direction by natural convection (20LFM).
- The iron base-plate dimension is 19" X 3.5" X 0.063" (The height is EIA standard 2U).
- The heat-sink is optional and P/N: 7G-0029B-F, 7G-0030B-F, 7G-0031B-F, 7G-0032B-F, 7GA0124P01-F, 7GA0125P01-F.

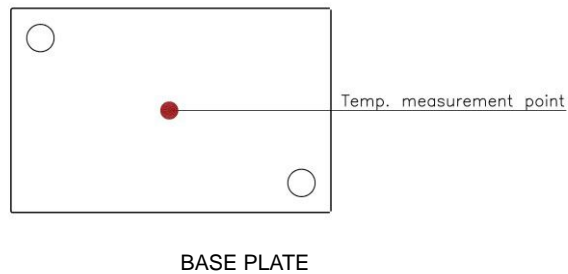

**HEAT-SINK TYPE OPTIONS**

**QAE60-□□S□□U -HS**  
7G-0029B-F

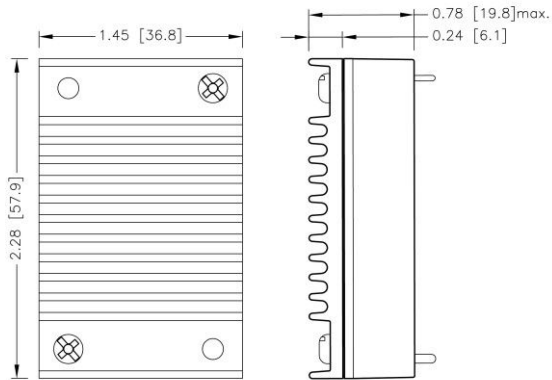

**QAE60-□□S□□U -HS1**  
7G-0030B-F

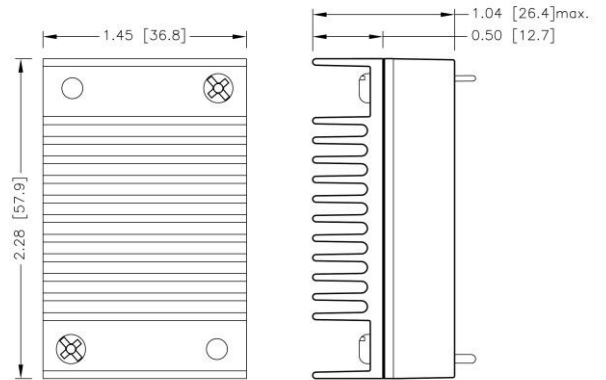

**QAE60-□□S□□U -HS2**  
7G-0031B-F

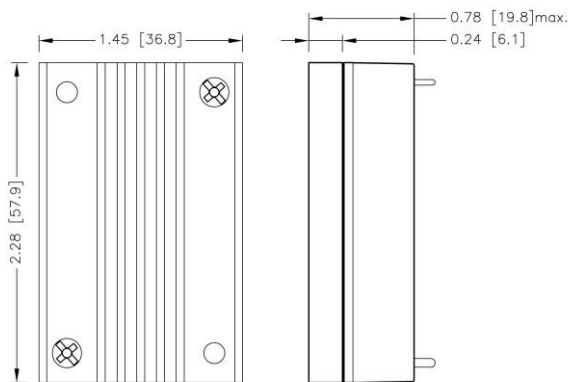

**QAE60-□□S□□U -HS3**  
7G-0032B-F

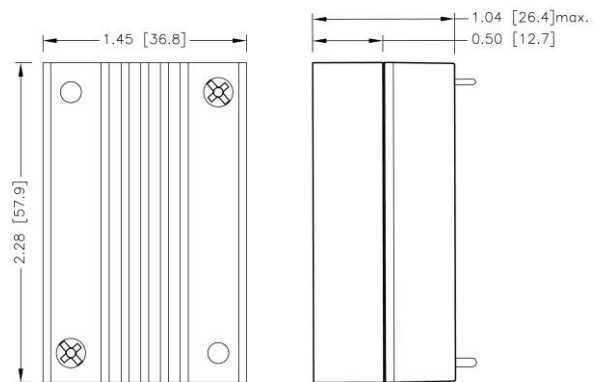

**QAE60-□□S□□U -HS4**  
7GA0124P01-F

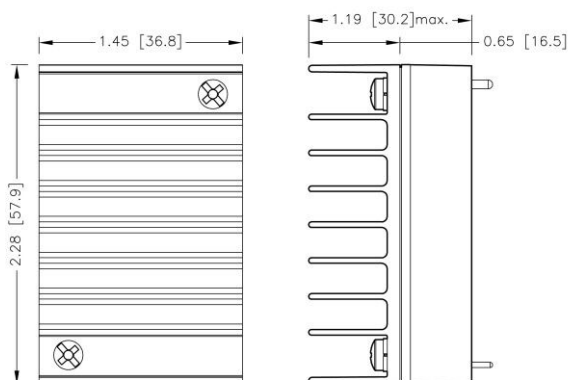

**QAE60-□□S□□U -HS5**  
7GA0125P01-F

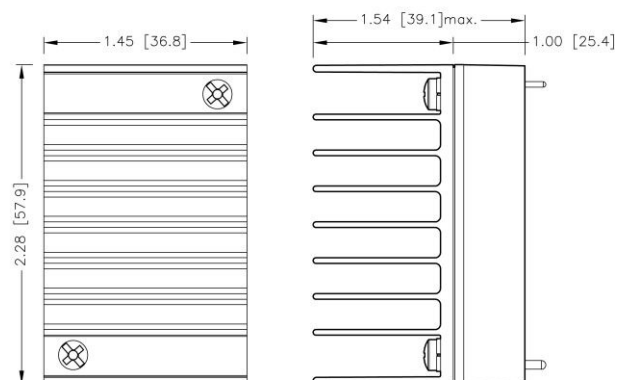

1. All dimensions in inch [mm]
2. Tolerance :x.xx±0.02 [x.x±0.5]

## TYPICAL APPLICATION

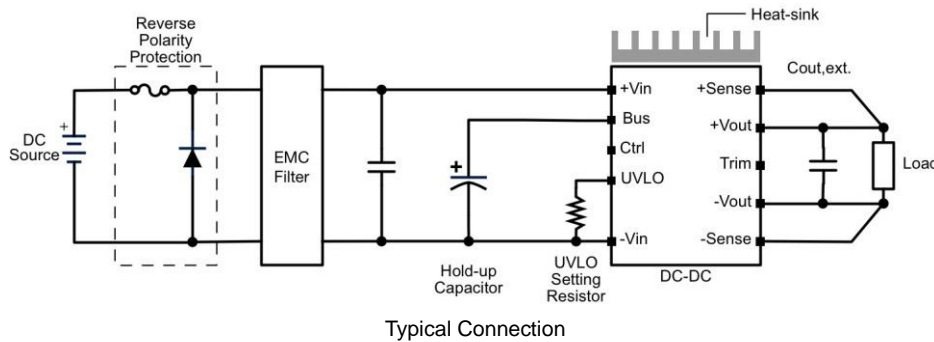

### UVLO

This series product has ultra wide input range. It could cover many kind of nominal input voltage in one module. In order to preventing incorrect operating under different input system, it offers UVLO adjustment by connecting a resistor to set UVLO threshold.

### UVLO Constants

Model	A	B	C
QAE60-36S□□U	48000	8273	0.96
QAE60-72S□□U	120000	12500	2.4

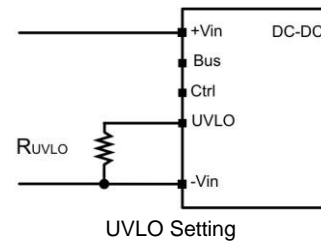

### UVLO Equation

Start-up Voltage

$$V_{\text{start-up}} = 1.25 \times \left[ \frac{A \times (R_{\text{UVLO}} + B)}{R_{\text{UVLO}} \times B} + 1 \right]$$

Shutdown Voltage

$$V_{\text{shutdown}} = V_{\text{start-up}} - C$$

### UVLO values for various nominal input voltage and R<sub>UVLO</sub> table

#### QAE60-36S□□U

Nominal Vin	12V	24V	36V	48V
Start-up voltage	8.46 V	13.36 V	20.56 V	27.76 V
Shutdown voltage	7.5 V	12.4 V	19.6 V	26.8 V
UVLO Setting resistor	Open	12.35 KΩ	4.98 KΩ	3.12 KΩ

#### QAE60-72S□□U

Nominal Vin	24 V	36 V	48 V	72 V	96 V	110 V
Start-up voltage	14.8 V	22 V	29.2 V	43.6 V	58 V	66.4 V
Shutdown voltage	12.4 V	19.6 V	26.8 V	41.2 V	55.6 V	64 V
UVLO Setting resistor	96.77 KΩ	17.14 KΩ	9.40 KΩ	4.94 KΩ	3.35 KΩ	2.82 KΩ

### Hold Up Time

Generally, connecting a large number of hold up capacitors on input are necessary to get a long duration of hold up time for S2, C2 described in EN50155. The Bus pin features excellent function can simply connect capacitors to Bus pin with less quantity of capacitors. It helps reduce layout area and smooth the inrush current.

For further information, please contact P-DUKE.

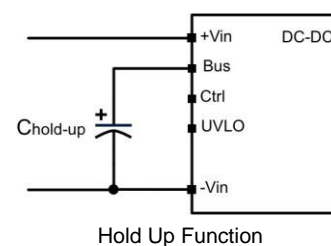

## OUTPUT VOLTAGE ADJUSTMENT

Output voltage is adjustable for 10% trim up or -20% trim down of nominal output voltage by connecting an external resistor between the Trim pin and either the +Sense or -Sense pins.

With an external resistor between the Trim and -Sense pin, the output voltage set point decreases.

With an external resistor between the Trim and +Sense pin, the output voltage set point increases.

Maximum output deviation is +10% inclusive of remote sense.

The external TRIM resistor needs to be at least 1/8W of rated power.

### Trim Up Equation

$$R_U = \left( \frac{5.11V_{OUT}(100 + \Delta\%)}{1.225\Delta\%} - \frac{511 + 10.22\Delta\%}{\Delta\%} \right) k\Omega$$

### Trim Down Equation

$$R_D = \left( \frac{511}{\Delta\%} - 10.22 \right) k\Omega$$

## EXTERNAL OUTPUT TRIMMING

Output can be externally trimmed by using the method shown below.

Trim-up

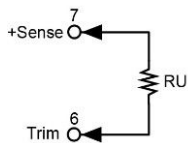

### □□S05U

ΔV (%)	1	2	3	4	5	6	7	8	9	10
Vout (V)	5.05	5.10	5.15	5.20	5.25	5.30	5.35	5.40	5.45	5.50
RU (kΩ)	1585.35	797.994	535.542	404.316	325.58	273.09	235.596	207.476	185.605	168.109

### □□S12U

ΔV (%)	1	2	3	4	5	6	7	8	9	10
Vout (V)	12.12	12.24	12.36	12.48	12.60	12.72	12.84	12.96	13.08	13.20
RU (kΩ)	4534.55	2287.19	1538.08	1163.52	938.78	788.956	681.939	601.676	539.25	489.309

### □□S15U

ΔV (%)	1	2	3	4	5	6	7	8	9	10
Vout (V)	15.15	15.30	15.45	15.60	15.75	15.90	16.05	16.20	16.35	16.50
RU (kΩ)	5798.49	2925.42	1967.73	1488.89	1201.58	1010.04	873.229	770.619	690.812	626.966

### □□S24U

ΔV (%)	1	2	3	4	5	6	7	8	9	10
Vout (V)	24.24	24.48	24.72	24.96	25.20	25.44	25.68	25.92	26.16	26.40
RU (kΩ)	9590.32	4840.11	3256.7	2465	1989.98	1673.3	1447.1	1277.45	1145.5	1039.94

### □□S28U

ΔV (%)	1	2	3	4	5	6	7	8	9	10
Vout (V)	28.28	28.56	28.84	29.12	29.40	29.68	29.96	30.24	30.52	30.80
RU (kΩ)	11275.58	5691.08	3829.58	2898.83	2340.38	1968.08	1702.151	1502.705	1347.58	1223.48

### □□S48U

ΔV (%)	1	2	3	4	5	6	7	8	9	10
Vout (V)	48.48	48.96	49.44	49.92	50.40	50.88	51.36	51.84	52.32	52.80
RU (kΩ)	19701.9	9945.94	6693.96	5067.97	4092.38	3441.99	2977.42	2628.99	2357.99	2141.19

### □□S53U

ΔV (%)	1	2	3	4	5	6	7	8	9	10
Vout (V)	53.53	54.06	54.59	55.12	55.65	56.18	56.71	57.24	57.77	58.30
RU (kΩ)	21808.437	11009.651	7410.056	5610.259	4530.38	3810.461	3296.233	2910.562	2610.596	2370.623

**OUTPUT VOLTAGE ADJUSTMENT(CONTINUED)**

Trim-down

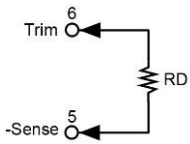

□□S□□U

$\Delta V$ (%)	1	2	3	4	5	6	7	8	9	10
RD (k $\Omega$ )	500.78	245.28	160.113	117.53	91.98	74.947	62.78	53.655	46.558	40.88
$\Delta V$ (%)	11	12	13	14	15	16	17	18	19	20
RD (k $\Omega$ )	36.235	32.363	29.088	26.28	23.847	21.718	19.839	18.169	16.675	15.33