



P-DUKE POWER

NSR01 Series

DC-DC Converter
Up to 15 Watts

3
YEARS
WARRANTY

ROHS
COMPLIANT

REACH
COMPLIANT

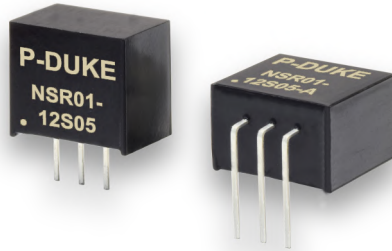

Automation



Datacom



IPC



Industry



Measurement



Telecom



Automobile



Boat



Charger



Medical



PV



Railway



NON
-isolation

LOW
Standby
Power

NO
Min. Load
Required

Positive
to
Negative
Output Appl.

OCP

OTP

SCP

PART NUMBER STRUCTURE

NSR01 - 12 S 05 - A

Series Name

Input
Voltage
(VDC)

Output
Quantity

Output
Voltage
(VDC)

Mounting
Options

See table

S:Single

See table

□: Vertical Mounting
A: Horizontal Mounting

TECHNICAL SPECIFICATION All specifications are typical at nominal input, full load and 25°C unless otherwise noted
POSITIVE OUTPUT APPLICATION

Model Number	Input Range VDC	Output Voltage VDC	Output Current @Full Load A	Input Current @ No Load mA	Efficiency		Maximum Capacitor Load μF
					Min. Vin %	Max. Vin %	
NSR01-12S1P2	4.6 ~ 36	1.2	1	1.0	73.0	62.0	470
NSR01-12S1P5	4.6 ~ 36	1.5		1.0	77.0	66.5	
NSR01-12S1P8	4.6 ~ 36	1.8		1.0	80.5	70.0	
NSR01-12S2P5	4.6 ~ 36	2.5		1.0	83.5	75.5	
NSR01-12S3P0	4.6 ~ 36	3.0		1.5	86.5	78.5	
NSR01-12S3P3	4.6 ~ 36	3.3		1.5	87.5	79.5	
NSR01-12S05	6.5 ~ 36	5.0		2.5	91.5	83.0	
NSR01-12S6P5	8.0 ~ 36	6.5		3.0	93.0	86.0	
NSR01-12S09	10.5 ~ 36	9.0		3.5	94.5	88.5	
NSR01-24S12	13.5 ~ 36	12		2.5	95.0	91.5	
NSR01-24S15	16.5 ~ 36	15		3.5	95.5	92.5	

NEGATIVE OUTPUT APPLICATION

Model Number	Input Range VDC	Output Voltage VDC	Output Current @Full Load A	Input Current @ No Load mA	Efficiency		Maximum Capacitor Load μF
					Min. Vin %	Max. Vin %	
NSR01-12S1P2	4.6 ~ 32	-1.2	-0.6	1.0	62.0	61.0	470
NSR01-12S1P5	4.6 ~ 32	-1.5	-0.6	1.0	69.5	64.5	
NSR01-12S1P8	4.6 ~ 32	-1.8	-0.6	1.0	72.0	67.5	
NSR01-12S2P5	4.6 ~ 32	-2.5	-0.6	1.0	72.0	74.0	
NSR01-12S3P0	4.6 ~ 32	-3.0	-0.6	2.0	73.0	76.5	
NSR01-12S3P3	4.6 ~ 32	-3.3	-0.6	2.0	74.0	77.5	
NSR01-12S05	4.6 ~ 31	-5.0	-0.4	3.0	79.5	78.5	
NSR01-12S6P5	7.0 ~ 29	-6.5	-0.3	4.0	84.5	80.0	
NSR01-12S09	7.0 ~ 27	-9.0	-0.3	7.0	85.0	82.0	
NSR01-24S12	7.0 ~ 24	-12	-0.3	8.0	85.0	85.5	
NSR01-24S15	7.0 ~ 21	-15	-0.2	10	85.5	84.5	

INPUT SPECIFICATIONS

Parameter	Conditions	Min.	Typ.	Max.	Unit
Operating input voltage range	Positive application	4.6		36	VDC
	Negative application			32	
Start up time	Constant resistive load Power up		5		ms
Rise time	Time for Vout rises from 10% to 90% of Vout		3.5		ms
Input filter			Capacitor type		
Input reflected ripple current			100		mAp-p

OUTPUT SPECIFICATIONS

Parameter	Conditions	Min.	Typ.	Max.	Unit
Voltage accuracy		-2.0		+2.0	%
Line regulation	Low Line to High Line at Full Load	-0.2		+0.2	%
Load regulation	10% to 100% of Full Load Vertical mounting	1.5Vout		+0.6	%
		Others		+0.4	
	Horizontal mounting	1.5Vout, 1.8Vout		+1.2	
		Others		+0.4	
Ripple and noise	Measured by 20MHz bandwidth Vout ≤ 6.5VDC Vout ≥ 9.0VDC		50 75		mVp-p
Temperature coefficient		-0.015		+0.015	%/°C
Dynamic load response	50% load step change	Peak deviation	150	250	mV
		Recovery time	250	350	µs
Output start-up overshoot				+1	%
Over load protection			2		A
Short circuit protection		Continuous, automatic recovery			

GENERAL SPECIFICATIONS

Parameter	Conditions	Min.	Typ.	Max.	Unit
Switching frequency	Vout ≤ 3.3VDC	240	300	360	kHz
	Vout ≥ 5.0VDC	464	580	696	
Safety meets		IEC/ EN/ UL62368-1			
Case material		Non-conducted black plastic			
Potting material		Silicone (UL94 V-0)			
Weight		1.9g (0.067oz)			
MTBF	MIL-HDBK-217F, Full load	2.009×10 ⁷ hrs			

ENVIRONMENTAL SPECIFICATIONS

Parameter	Conditions	Min.	Typ.	Max.	Unit
Operating ambient temperature	With derating	-40		+100	°C
Over temperature protection	Internal IC junction		170		°C
Storage temperature range		-55		+125	°C
Thermal shock		MIL-STD-810F			
Shock		MIL-STD-810F			
Vibration		MIL-STD-810F			
Relative humidity		5% to 95% RH			

CAUTION: This power module is not internally fused. An input line fuse must always be used.

NEGATIVE OUTPUT APPLICATION

Figure 1

C1 and C2 are required that should be fitted close to the converter's pins.
Maximum capacitive load including C2 is 470µF.

CHARACTERISTIC CURVE

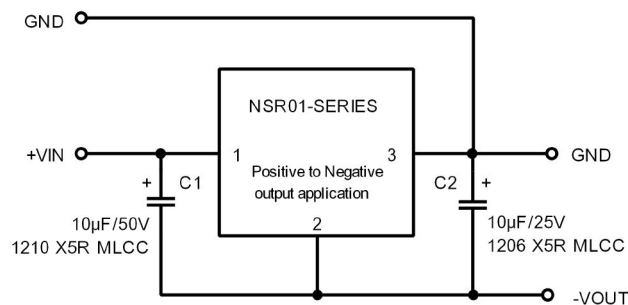
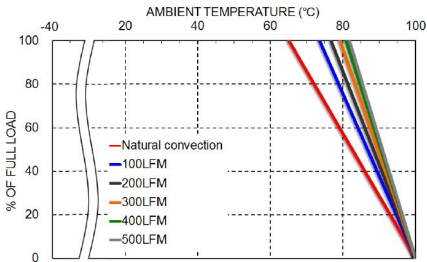

NSR01-12S05; Derating Curve
Positive application

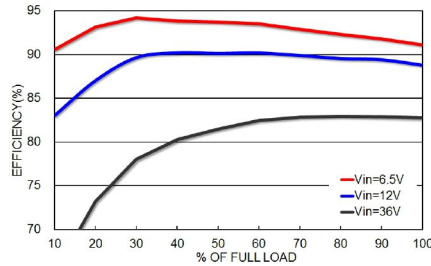

NSR01-12S05; Efficiency vs. load
Positive application

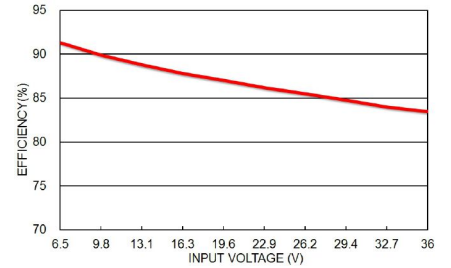

NSR01-12S05; Efficiency vs. line
Positive application

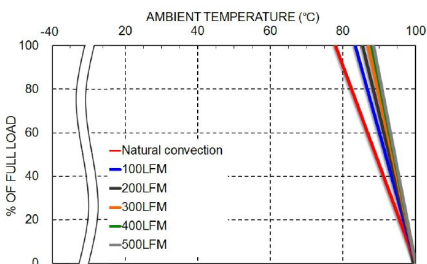

NSR01-12S05; Derating Curve
Negative application

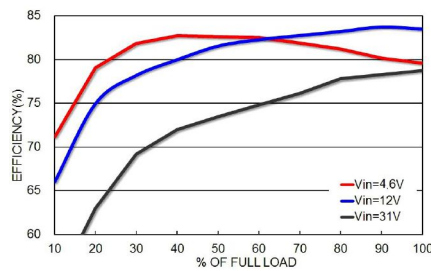

NSR01-12S05; Efficiency vs. load
Negative application

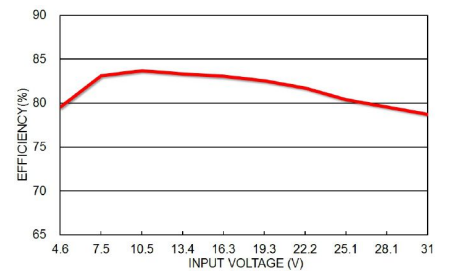

NSR01-12S05; Efficiency vs. line
Negative application

FUSE CONSIDERATION

This power module is not internally fused. An input line fuse must always be used.

This encapsulated power module can be used in a wide variety of applications, ranging from simple stand-alone operation to an integrated part of sophisticated power architecture.

To maximum flexibility, internal fusing is not included; however, to achieve maximum safety and system protection, always use an input line fuse.

The input line fuse suggest as below :

Model	Fuse Rating (A)	Fuse Type
NSR01-□□S□□	2.0	Slow-Blow

The table based on the information provided in this data sheet on inrush energy and maximum DC input current at low Vin.

MECHANICAL DRAWING

Standard type: Vertical mounting

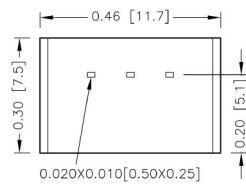
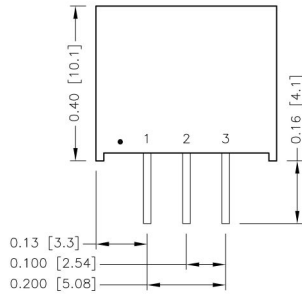

BOTTOM VIEW

PIN CONNECTION

PIN	DEFINE
1	+Vin
2	GND
3	+Vout

1. All dimensions in inch [mm]
2. Tolerance :x.xx±0.02 [x.x±0.5]
x.xxx±0.01 [x.xx±0.25]
3. Pin dimension tolerance ±0.004[0.10]

Suffix-A: Horizontal mounting

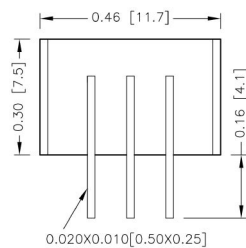
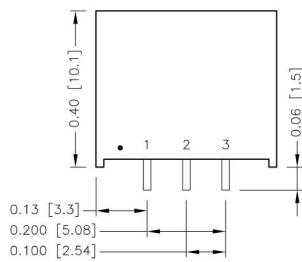

BOTTOM VIEW

RECOMMENDED PAD LAYOUT

Standard type: Vertical mounting

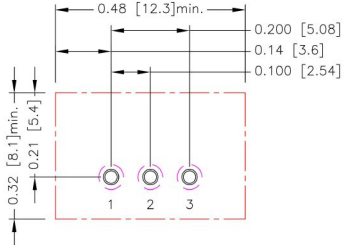

Suffix-A: Horizontal mounting

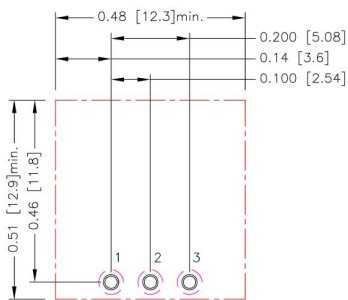

All dimensions in inch[mm]
 Pad size(lead free recommended)
 Through hole 1.2.3: $\varnothing 0.031[0.80]$
 Top view pad 1.2.3: $\varnothing 0.039[1.00]$
 Bottom view pad 1.2.3: $\varnothing 0.063[1.60]$

THERMAL CONSIDERATIONS

The power module operates in a variety of thermal environments.

However, sufficient cooling should be provided to help ensure reliable operation of the unit.

Heat is removed by conduction, convection, and radiation to the surrounding Environment.

Proper cooling can be verified by measuring the point as the figure below.

The temperature at this location should not exceed 100°C.

When Operating, adequate cooling must be provided to maintain the test point temperature at or below 100°C.

Although the maximum point Temperature of the power modules is 100°C, you can limit this Temperature to a lower value for extremely high reliability.

The unit will shutdown if the internal IC junction exceeds 170°C (typical), but the thermal shutdown is not intended as a guarantee that the unit will survive temperature beyond its rating. The module will automatically restarts after it cools down.

- Thermal test condition with vertical direction by natural convection (20LFM).

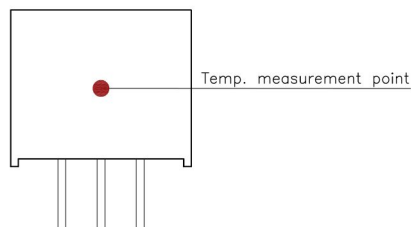

BACK VIEW