



P-DUKE POWER

TAF300 Series

2 X 4 Inch AC-DC POWER SUPPLIES
Up to 300 Watts

3
YEARS
WARRANTY

ROHS
COMPLIANT

REACH
COMPLIANT

+85°C
-40°C
AMBIENT TEMP.



Automation



Datacom



IPC



Industry



Measurement



Telecom



Automobile



Boat



Charger



Medical



PV



Railway

UL US CB CE UK CA



PEAK
POWER

3000
VAC
Reinforced
Insulation

ADJ.
Output
Voltage

Internal
EN55032
Class
Filter **B**

LOW
Leakage
Current

LOW
Standby
Power

Operating
Altitude
5000
meter

Protection
Class I
Class II

FAN
Speed
Control

REMOTE
ON
OFF

POWER
GOOD

OCP

OTP

OVP

SCP

OVCIII

PART NUMBER STRUCTURE

TAF300 **U** **S** **12** **A** - **M**

Series Name	Universal Input (VAC)	Output Quantity	Output Voltage (VDC)	Protection Type	Package Options	Application Options	Fan Control Options	Electrical Options
	85-264	Single	12:12V 15:15V 18:18V 24:24V 28:28V 36:36V 48:48V 53:53V	A: CLASS I B: CLASS II	<input type="checkbox"/> Open type <input type="checkbox"/> E1: Enclosed type <input type="checkbox"/> U2: Base plate type <input type="checkbox"/> D1: Din rail type	<input type="checkbox"/> AC Input <input type="checkbox"/> C: OVC III(2000m) <input type="checkbox"/> G: DC Input	F3: No External FAN with fixed fan speed control F4: No External FAN with variable fan speed control For E1/D1 Type Only F1: External FAN with fixed fan speed control F2: External FAN with variable fan speed control	<input type="checkbox"/> Standby power Remote control Power Good signal N: None

TECHNICAL SPECIFICATION All specifications are typical at 230VAC input, full load and 25°C unless otherwise noted

Model Number	Input Range	Output Voltage	Output Current		Input Power @ No Load	Efficiency	Maximum Capacitor Load
			Natural Convection	Forced Air Cooling With 21 CFM			
			VAC	VDC			
TAF300US12A-MF3	85 ~ 264	12	15	25	0.3	91	20000
TAF300US15A-MF3	85 ~ 264	15	12	20	0.3	92	12000
TAF300US18A-MF3	85 ~ 264	18	10	16.66	0.3	93	9000
TAF300US24A-MF3	85 ~ 264	24	7.5	12.5	0.3	93	2400
TAF300US28A-MF3	85 ~ 264	28	6.42	10.71	0.3	93	2000
TAF300US36A-MF3	85 ~ 264	36	5	8.33	0.3	93	1000
TAF300US48A-MF3	85 ~ 264	48	3.75	6.25	0.3	93	650
TAF300US53A-MF3	85 ~ 264	53	3.4	5.67	0.3	93	470

INPUT SPECIFICATIONS						
Parameter	Conditions		Min.	Typ.	Max.	Unit
Operating input voltage range	AC input		85		264	VAC
	DC input		120		370	VDC
Input frequency	AC input		47		63	Hz
Input current	100VAC and Full Load				3.9	A
	240VAC and Full Load				1.6	
No load input power	230VAC	Option-F(with Fan)		3		Watts
		Others		0.3		
Leakage current	264VAC				300	μA
Power Factor	230VAC and Full Load		0.9			
Start up time					2000	ms
Rise time				30		ms
Hold up time	115VAC and 225W		10			ms
Input inrush current	230VAC	Cold start			70	A
Input protection	Internal fuse in line and neutral				T5.0A/250VAC	

OUTPUT SPECIFICATIONS						
Parameter	Conditions		Min.	Typ.	Max.	Unit
Output power	Forced air cooling				300	Watts
	Natural convection				180	
Output peak power	Peak power				360	Watts
	Peak power time			5		s
	Peak power duty			20		%
	Average operation power (% of Full Load)			50		%
Initial set voltage accuracy	230VAC and Full Load		-1.0		+1.0	%
Line regulation	Low Line to High Line at Full Load		-0.2		+0.2	%
Load regulation	No Load to Full Load		-0.5		+0.5	%
	10% Load to 90% Load		-0.4		+0.4	%
Voltage adjustability	Maximum output deviation is inclusive of remote sense		-10		+10	%
Minimum load				0		%
Ripple and noise	Measured by 20MHz bandwidth					
	With a 1μF/100V 1206 X7R MLCC					
		12Vout		120		
		15Vout		150		
		18Vout		180		
		24Vout		240		mVp-p
		28Vout		280		
		36Vout		360		
	48Vout		480			
	53Vout		530			
Temperature coefficient			-0.02		+0.02	%/°C
Transient response	Load step from 50 ~ 75% change at 2.5A/μs	Peak deviation		3		% Vout
	Recovery within 1% Vout	Recovery time		600		μs
Over voltage protection	% of Vout(nom); Latch mode		115		135	%
Over load protection	% of Iout rated; Hiccup mode			150		%
Short circuit protection			Continuous, automatic recovery			
Main output remote control	Positive Logic Referenced to "-Control" *Standby power always present	Main power ON	Open or 3 ~ 12 VDC			
		Main power OFF	Short or 0 ~ 1.2VDC			
Main output Power Good signal	Referenced to "GND"	Input current of Control	-0.5		1	mA
		Power good				Low
		Power off				Open collector
Standby power supply	Standby and fan power supply total power 8W				1000	mA
Fan power supply					500	mA

GENERAL SPECIFICATIONS

Parameter	Conditions	Min.	Typ.	Max.	Unit
Isolation voltage	1 minute (Reinforced insulation) Input to Output Input (Output) to F.G.	3000 2000			VAC
Isolation resistance	500VDC	0.1			GΩ
Switching frequency	230VAC, Full load		140		kHz
Safety approvals	IEC/ EN/ UL 62368-1				UL:E193009 CB:UL(Demko)
Weight	Open type Enclosed type Base plate type Din rail type				210g (7.40oz) 318g (11.21oz) 260g (9.17oz) 340g (11.99oz)
MTBF	MIL-HDBK-217F Ta=25°C, Full load				1.056 x 10 ⁶ hrs

ENVIRONMENTAL SPECIFICATIONS

Parameter	Conditions	Min.	Typ.	Max.	Unit
Operating ambient temperature	With derating Option -F (With Fan) Others	-40 -40		+80 +85	°C
Storage temperature range	Option -F (With Fan) Others	-40 -40		+80 +85	°C
Over temperature protection	Internal thermistor ; Hiccup mode		125		°C
Operating altitude				5000	m
Shock					IEC60068-2-27
Vibration					IEC60068-2-6
Relative humidity	Non-condensing				5% to 95% RH

EMC SPECIFICATIONS

Parameter	Conditions	Level	
EMI	EN55032 and FCC Part 15	Conducted Radiated	Class B Class A
Harmonic currents	EN61000-3-2 Full Load		Class A
Voltage flicker	EN61000-3-3		
EMS	EN55035		
ESD	EN61000-4-2		Perf. Criteria A
Radiated immunity	EN61000-4-3 20 V/m		Perf. Criteria A
Fast transient	EN61000-4-4 ± 2kV		Perf. Criteria A
Surge	EN61000-4-5 DM ± 1kV and CM ± 2kV		Perf. Criteria A
Conducted immunity	EN61000-4-6 20 Vr.m.s		Perf. Criteria A
Power frequency magnetic field	EN61000-4-8 30 A/m		Perf. Criteria A
Dip and interruptions	EN61000-4-11		

CHARACTERISTIC CURVE

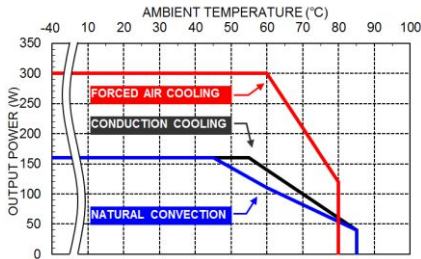

Derating Curve vs. Ambient Temperature
Vin=115VAC Open type

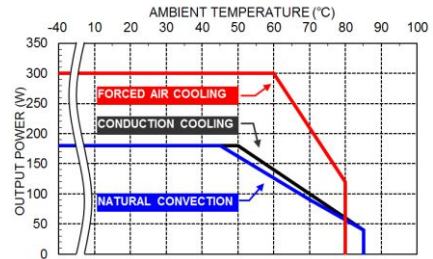

Derating Curve vs. Ambient Temperature
Vin=230VAC Open type

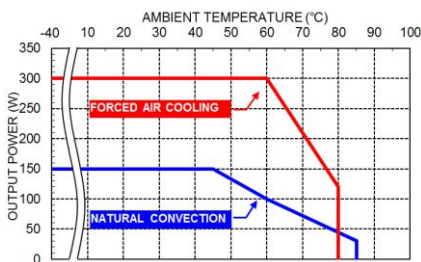

Derating Curve vs. Ambient Temperature
Vin=115VAC Enclosed type / Din rail type

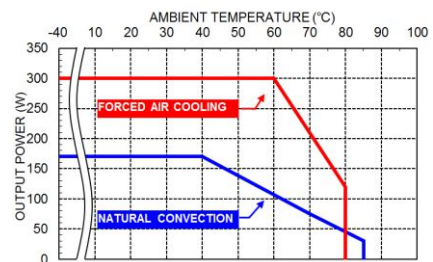

Derating Curve vs. Ambient Temperature
Vin=230VAC Enclosed type / Din rail type

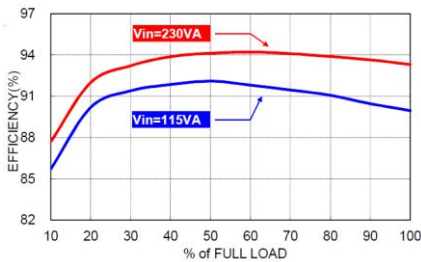

Efficiency vs. Output Load
TAF300US24 with Forced air cooling

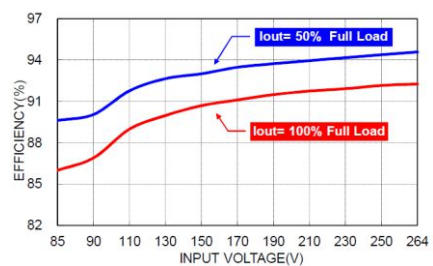

Efficiency vs. Input Voltage
TAF300US24 with Forced air cooling

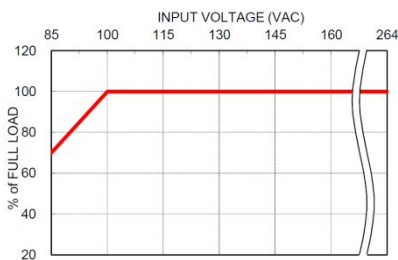

Derating Curve vs. Input Voltage
TAF300

MECHANICAL DRAWING

Open type- AC Input

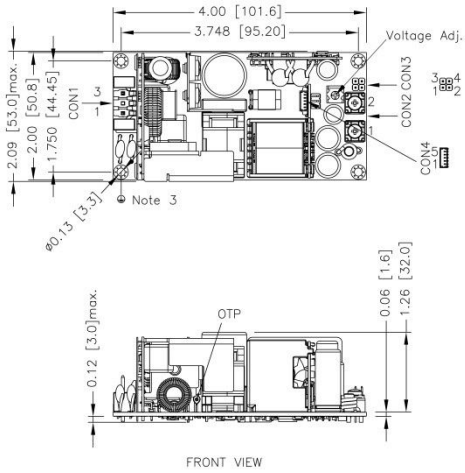

Open type- DC Input

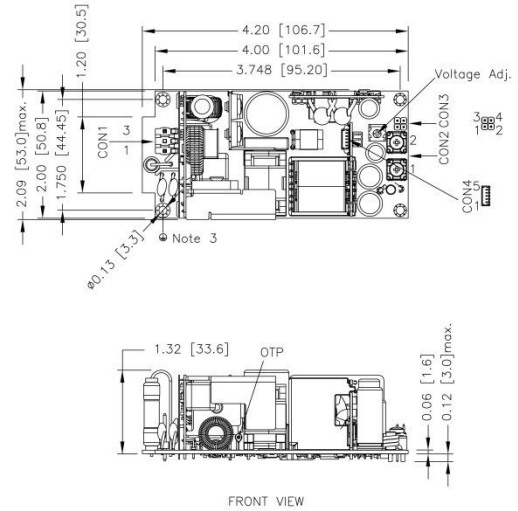

- 1.All dimensions in inch [mm]
Tolerance : $x.xx \pm 0.02$ [$x.x \pm 0.5$]
 $x.xxx \pm 0.01$ [$x.xx \pm 0.25$]
- 2.The CON2 locked torque: MAX 16.8Kgf.cm/1.65N.m
- 3.The screws holes can be considered as PE connection for CLASS I application.

- 1.All dimensions in inch [mm]
Tolerance : $x.xx \pm 0.02$ [$x.x \pm 0.5$]
 $x.xxx \pm 0.01$ [$x.xx \pm 0.25$]
- 2.The CON2 locked torque: MAX 16.8Kgf.cm/1.65N.m
- 3.The screws holes can be considered as PE connection for CLASS I application.

Base plate type

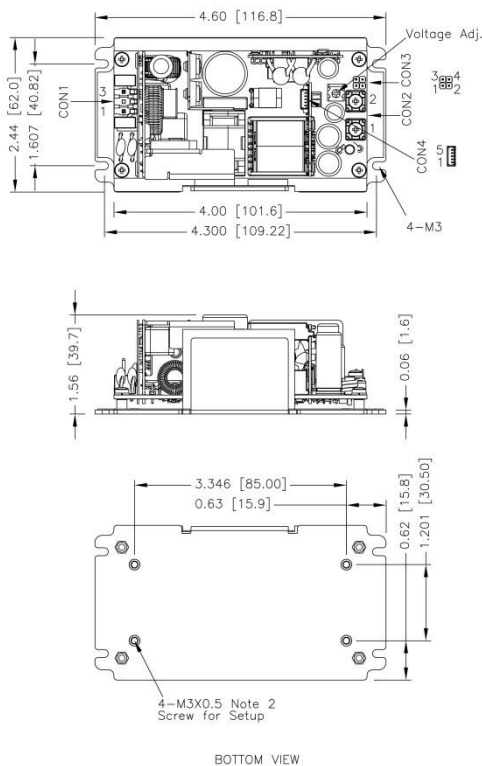

- 1.All dimensions in inch [mm]
Tolerance : $x.xx \pm 0.02$ [$x.x \pm 0.5$]
 $x.xxx \pm 0.01$ [$x.xx \pm 0.25$]
- 2.The screw locked torque: MAX 5Kgf.cm/0.49N.m
- 3.The CON2 locked torque: MAX 16.8Kgf.cm/1.65N.m

MECHANICAL DRAWING

Enclosed type with FAN

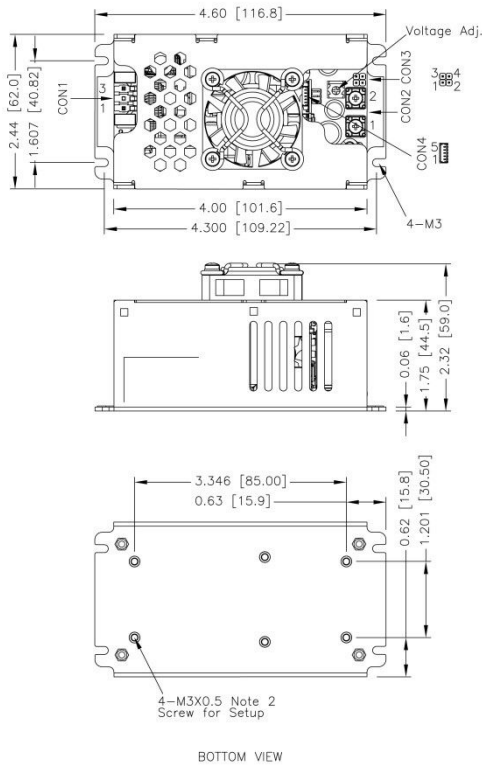

1.All dimensions in inch [mm]

Tolerance : $x.xx \pm 0.02$ [$x.x \pm 0.5$]
 $x.xxx \pm 0.01$ [$x.xx \pm 0.25$]

- 2.The screw locked torque: MAX 5Kgf.cm/0.49N.m
 3.The CON2 locked torque: MAX 16.8Kgf.cm/1.65N.m

Din rail type with FAN

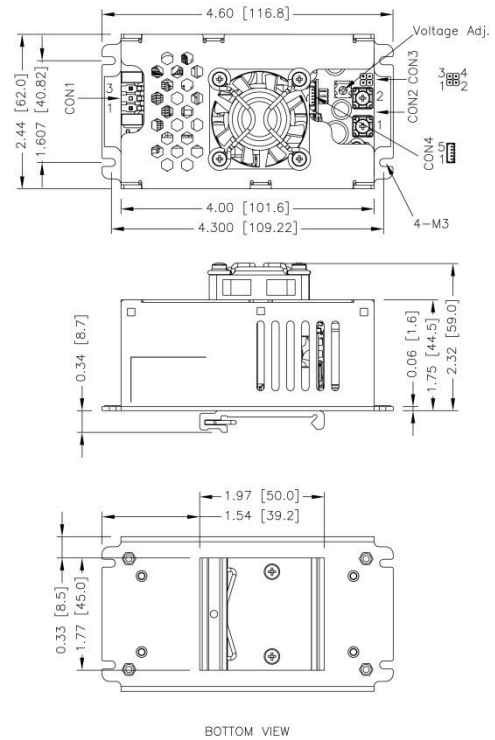

1.All dimensions in inch [mm]

Tolerance : $x.xx \pm 0.02$ [$x.x \pm 0.5$]
 $x.xxx \pm 0.01$ [$x.xx \pm 0.25$]

- 2.The CON2 locked torque: MAX 16.8Kgf.cm/1.65N.m

CONNECTOR CONNECTIONS

CON1 – Input Connector

Pin Number	AC Input	DC Input
Pin 3	Line	DC+
Pin 1	Neutral	DC-

Mates with
 Molex housing : **09-50-8031**
 Molex crimp terminals : **2478,6838,45570**

CON3 – Aux Connector

Pin 1	+Fan
Pin 2	-Fan
Pin 3	+V Sense
Pin 4	-V Sense

Mates with
 Molex housing : **90143-0004**
 Molex crimp terminals : **90119**

CON2 – Output Connector

Pin 1	+Vout
Pin 2	-Vout

Mates with
 KST ring terminal : **RVS2-3.7**

CON4 – Aux Connector

Pin 1	+Standby
Pin 2	-Standby
Pin 3	+PG
Pin 4	-Control
Pin 5	+Control

Mates with
 Molex housing : **51021-0500**
 Molex crimp terminals : **50058,50079**