

Chrome DIN Rail Power Supply

24V 91.2W 1 Phase (Class II & NEC Class 2) / DRC-24V100W1A□



*This picture is for reference to DRC-24V100W series only.

CHROME

Highlights & Features

- Class II Double Isolation (No Earth connection is required)
- Universal AC input voltage range and full power up to 55°C
- Power will not de-rate for the entire input voltage range
- Efficiency > 89.0% @ 230 Vac
- Can be installed in compact cabinets
- NEC Class 2 and Limited Power Source (LPS) approvals
- Conforms to harmonic current IEC/EN 61000-3-2, Class A
- Safety approval according to IEC/EN/UL 60950-1, IEC/EN/UL 62368-1 and UL 508

Safety Standards



CB Certified for worldwide use

Model Number: DRC-24V100W1A□
Unit Weight: 0.35 kg (0.77 lb)
Dimensions (L x W x D): 91.0 x 89.9 x 55.6 mm
 (3.58 x 3.54 x 2.19 inch)

General Description

The DRC-24V100W1A□ is part of the Chrome DIN rail power supply series, which is designed for use in compact cabinets for home automations and the food and beverage industry. Delta's Chrome DIN rail power supply series offers double isolated input. This means that no Earth connection is required thus resulting in low leakage current. This product provides a universal input voltage range of 90-264 Vac, and a wide temperature range of -25°C to 71°C. The Chrome series is certified to safety standard according to IEC 60950-1, IEC/EN/BS EN UL 62368-1 and UL 508. NEC Class 2 and Limited Power Source (LPS) approvals are available for this product.

Model Information

Chrome DIN Rail Power Supply

| Model Number | Input Voltage Range | Rated Output Voltage | Rated Output Current |
|----------------|--------------------------|----------------------|----------------------|
| DRC-24V100W1A□ | 90-264 Vac (125-375 Vdc) | 24 Vdc | 3.80 A |

Model Numbering

| DR | C - | 24V | 100W | 1 | A | □ |
|----------|---|----------------|-----------------------------|--------------|--------|--|
| DIN Rail | Product Series C - Isolation Class II Power Supply | Output Voltage | Output Power (100 W series) | Single Phase | No PFC | C - Black Plastic case with conformal Coating Z - Black Plastic case without conformal Coating G - Grey Plastic case without conformal Coating |

Chrome DIN Rail Power Supply

24V 91.2W 1 Phase (Class II & NEC Class 2) / DRC-24V100W1A□

Specifications

Input Ratings / Characteristics

| | |
|---------------------------------|--|
| Nominal Input Voltage | 100-240 Vac |
| Input Voltage Range | 90-264 Vac |
| Nominal Input Frequency | 50-60 Hz |
| Input Frequency Range | 47-63 Hz |
| Nominal DC Input Voltage* | 125-250 Vdc |
| DC Input Voltage Range* | 125-375 Vdc |
| Input Current | < 2.20 A @ 115 Vac, < 1.00 A @ 230 Vac |
| Efficiency at 100% Load | > 87.0% @ 115 Vac, > 89.0% @ 230 Vac |
| Max Power Dissipation | 0% load < 0.4 W @ 115 Vac & 230 Vac |
| | 100% load < 13.6 W @ 115 Vac, < 11.2 W @ 230 Vac |
| Max Inrush Current (Cold Start) | < 30 A @ 115 Vac, < 60 A @ 230 Vac |
| Leakage Current | < 0.25 mA @ 240 Vac |

*Safety approval according to IEC/EN/UL 60950-1.

Output Ratings / Characteristics**

| | |
|--|---|
| Nominal Output Voltage | 24 Vdc |
| Factory Set Point Tolerance | 24 Vdc \pm 2% |
| Output Voltage Adjustment Range | 22-24 Vdc |
| Output Current | 0-3.80 A (3.80 A max.) |
| Output Power | 91.2 W |
| Line Regulation | < 0.5% (@ 90-264 Vac input, 100% load) |
| Load Regulation | < 1.0% (@ 90-264 Vac input, 0-100% load) |
| PARD*** (20 MHz) | < 100 mVpp |
| Rise Time | < 70 ms @ nominal input (100% load) |
| Start-up Time | < 2,000 ms @ nominal input (100% load) |
| Hold-up Time | > 10 ms @ 115 Vac, |
| | > 60 ms @ 230 Vac (100% load) |
| Dynamic Response (Overshoot & Undershoot O/P Voltage) | \pm 5% @ 90-264 Vac input, 10-100% load (Slew Rate: 0.1 A/ μ s, 50% duty cycle @ 5 Hz to 100 Hz) |
| Start-up with Capacitive Loads | 3,000 μ F Max |

**For power de-rating from 55°C to 70°C, see power de-rating on page 3.

***PARD is measured with an AC coupling mode, 5 cm wires, and in parallel with 0.1 μ F ceramic capacitor & 47 μ F electrolytic capacitor.

Chrome DIN Rail Power Supply

24V 91.2W 1 Phase (Class II & NEC Class 2) / DRC-24V100W1A□

Mechanical

| | | |
|-----------------------------------|--|---------------------------|
| Case Cover | Plastic | |
| Dimensions (L x W x D) | 91.0 x 89.9 x 55.6 mm (3.58 x 3.54 x 2.19 inch) | |
| Unit Weight | 0.35 kg (0.77 lb) | |
| Indicator | Green LED | DC OK |
| Cooling System | Convection | |
| Terminal | Input | 2 Pins (Rated 300 V/25 A) |
| | Output | 4 Pins (Rated 300 V/25 A) |
| Wire | Input / Output | AWG 20-12 |
| Mounting Rail | Standard TS35 DIN Rail in accordance with EN 60715 | |
| Noise (1 Meter from power supply) | Sound Pressure Level (SPL) < 25 dBA | |

Environment

| | | |
|-----------------------------|-------------------------------|---|
| Surrounding Air Temperature | Operating | -25°C to +71°C |
| | Storage | -25°C to +85°C |
| Power De-rating | Temperature | > 55°C de-rate power by 2.5% / °C |
| Operating Humidity | 5 to 95% RH (Non-Condensing) | |
| Operating Altitude | 0 to 2,000 Meters (6,560 ft.) | |
| Shock Test | Operating | IEC 60068-2-27, Half Sine Wave: 4 G for a duration of 22 ms, 3 shocks for each 3 directions, 9 times in total |
| Vibration | Operating | IEC 60068-2-6, Sine Wave: 10-500 Hz @ 19.6 m/S ² (2 G peak); 10 min per cycle, 60 min for all X, Y, Z directions |
| Over Voltage Category | II | |
| Pollution Degree | 2 | |

Protections

| | |
|--------------------------|---|
| Overvoltage | < 34.8 V, SELV Output, Latch Mode |
| Overload / Overcurrent | > 102~108% of rated load current, Fold Forward Mode (current rises, voltage drops) Non-Latching (Auto-Recovery) |
| Over Temperature | > 75°C Surrounding Air Temperature @ 100% load, Latch Mode |
| Short Circuit | Hiccup Mode, Non-Latching (Auto-Recovery when the fault is removed) |
| Internal Fuse at L pin | T3.15 AH |
| Degree of Protection | IP20 |
| Protection Against Shock | Class II (No PE* connection is required) |

*PE: Primary Earth

Reliability Data

| | |
|------------------------|--|
| MTBF | > 500,000 hrs. as per Telcordia SR-332 I/P: 100 Vac, O/P: 100% load, Ta: 35°C |
| Expected Cap Life Time | 10 years (115 Vac & 230 Vac, 50% load @ 40°C) |

Chrome DIN Rail Power Supply

24V 91.2W 1 Phase (Class II & NEC Class 2) / DRC-24V100W1A□

Safety Standards / Directives

| | | |
|------------------------------|-------------------|---|
| Safety Entry Low Voltage | | SELV (IEC 60950-1) |
| Electrical Safety | TUV Bauart | EN 62368-1 |
| | UL/cUL recognized | UL 60950-1 and CSA C22.2 No. 60950-1 (File No. E131881) UL 62368-1 and CSA C22.2 No. 62368-1 (File No. E131881) |
| | CB scheme | IEC 60950-1, IEC 62368-1, Limited Power Source (LPS) |
| | UKCA | BS EN 62368-1 |
| Industrial Control Equipment | UL/cUL listed | UL 508 and CSA C22.2 No. 107.1-01 (File No. E338991) |
| Class 2 Power Supply | UL/cUL recognized | UL 60950-1 and CSA C22.2 No. 60950-1 (File No. E131881) UL 62368-1 and CSA C22.2 No. 62368-1 (File No. E131881) |
| BIS | | IS 13152-1 |
| CE | | In conformance with EMC Directive 2014/30/EU and Low Voltage Directive 2014/35/EU |
| UKCA | | In conformance with Electrical Equipment (Safety) Regulations 2016 No. 1011 and The Electromagnetic Compatibility Regulations 2016 No. 1091 |
| Galvanic Isolation | Input to Output | 3.0 KVac |

EMC

| | | | |
|-----------------------------------|----------------|--|--|
| Emissions (CE & RE) | | Generic Standards: CISPR 32, EN/BS EN 55032, FCC Title 47: Class B | |
| Immunity | | Generic Standards: EN/BS EN 55024 | |
| Electrostatic Discharge | IEC 61000-4-2 | Level 3 Criteria A ¹⁾ Air Discharge: 8 kV Contact Discharge: 4 kV | |
| Radiated Field | IEC 61000-4-3 | Level 2 Criteria A ¹⁾ 80 MHz - 1 GHz, 3 V/M with 1 kHz tone / 80% modulation | |
| Electrical Fast Transient / Burst | IEC 61000-4-4 | Level 3 Criteria A ¹⁾ 1 kV | |
| Surge | IEC 61000-4-5 | Level 3 Criteria A ¹⁾ Differential Mode ³⁾ : 1 kV | |
| Conducted | IEC 61000-4-6 | Level 2 Criteria A ¹⁾ 150 kHz - 80 MHz, 3 Vrms | |
| Power Frequency Magnetic Fields | IEC 61000-4-8 | Criteria A ¹⁾ 1 A/Meter | |
| Voltage Dips and Interruptions | IEC 61000-4-11 | 0% of 100 Vac, 20 ms 40% of 100 Vac, 200 ms 70% of 100 Vac, 500 ms 0% of 100 Vac, 5,000 ms 0% of 240 Vac, 20 ms 40% of 240 Vac, 200 ms 70% of 240 Vac, 500 ms 0% of 240 Vac, 5,000 ms | Criteria B ²⁾ Criteria B ²⁾ Criteria A ¹⁾ Criteria B ²⁾ Criteria A ¹⁾ Criteria A ¹⁾ Criteria A ¹⁾ Criteria B ²⁾ |
| Harmonic Current Emission | | IEC/EN/BS EN 61000-3-2, Class A | |
| Voltage Fluctuation and Flicker | | IEC/EN/BS EN 61000-3-3 | |

1) Criteria A: Normal performance within the specification limits

2) Criteria B: Temporary degradation or loss of function which is self-recoverable

3) Symmetrical: Differential mode (Line to line)

Chrome DIN Rail Power Supply

24V 91.2W 1 Phase (Class II & NEC Class 2) / DRC-24V100W1A□

Block Diagram

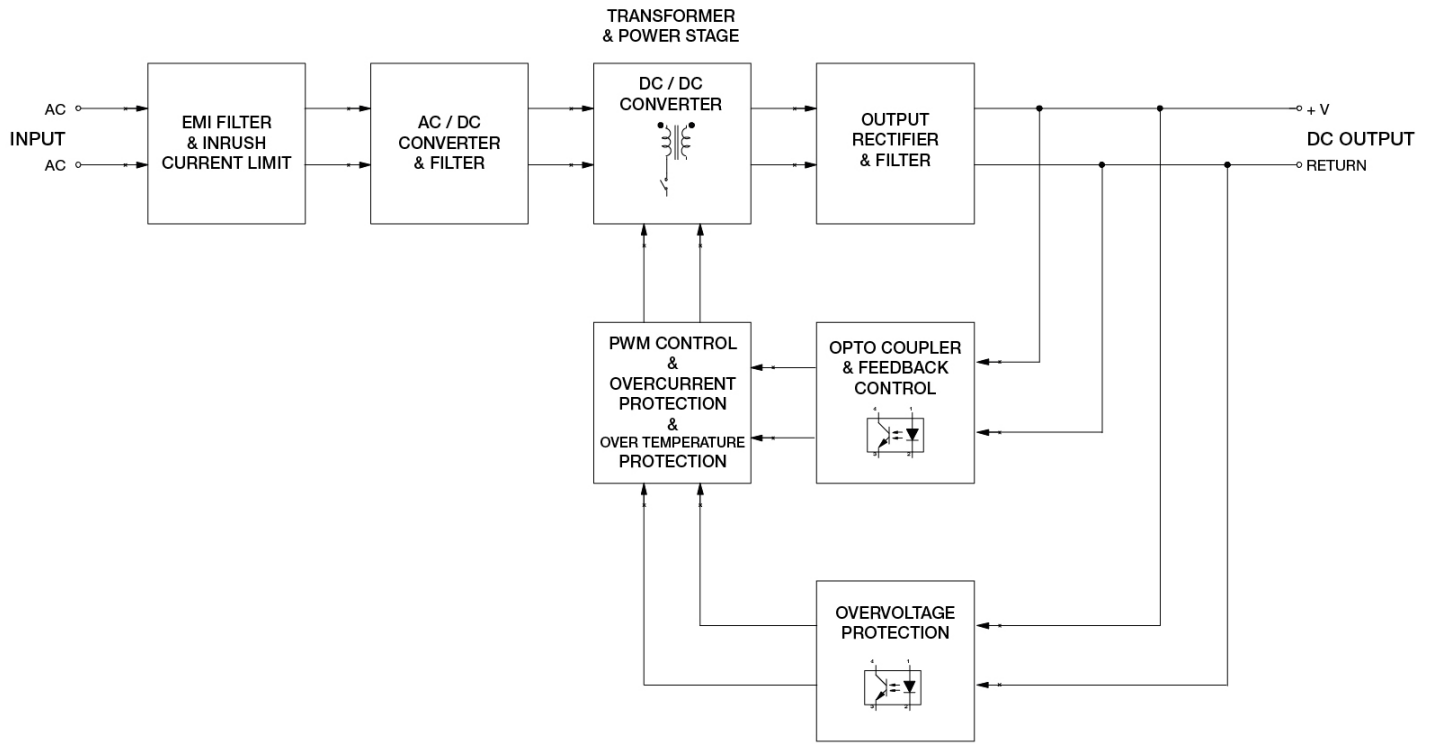

Device Description

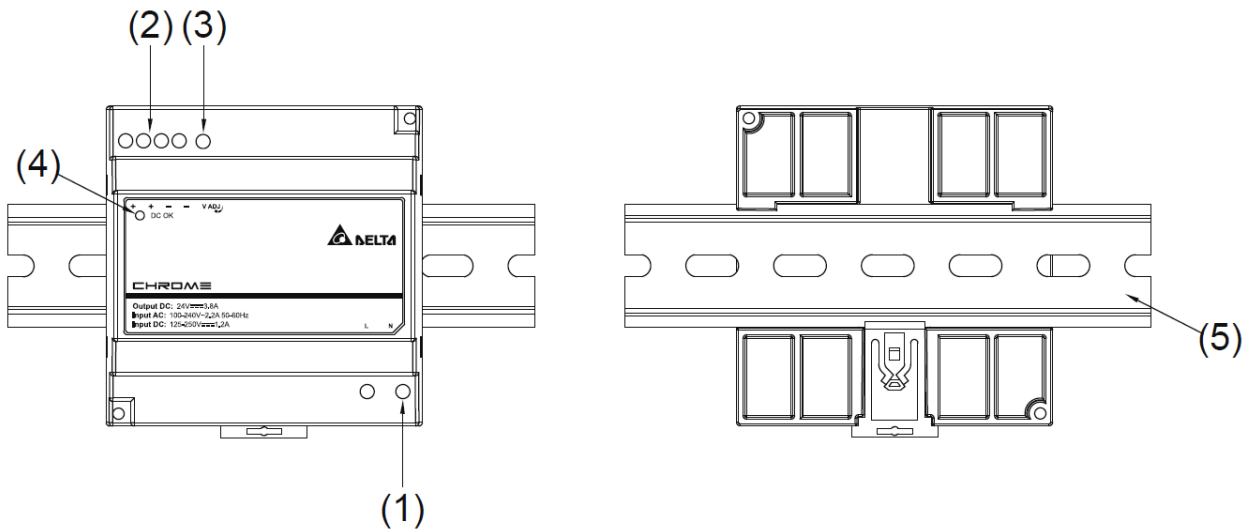

- 1) Input terminal block connector
- 2) Output terminal block connector
- 3) DC voltage adjustment potentiometer
- 4) DC OK control LED (Green)
- 5) Universal mounting system

Chrome DIN Rail Power Supply

24V 91.2W 1 Phase (Class II & NEC Class 2) / DRC-24V100W1A □

Dimensions

L x W x D: 91.0 x 89.9 x 55.6 mm (3.58 x 3.54 x 2.19 inch)

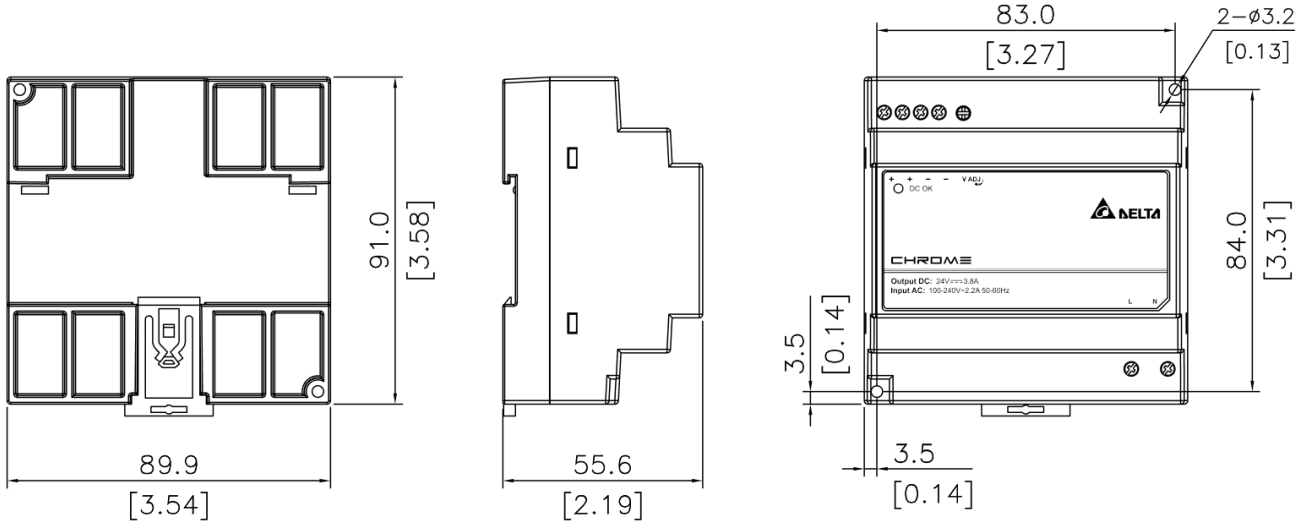

Engineering Data

Output Load De-rating VS Surrounding Air Temperature

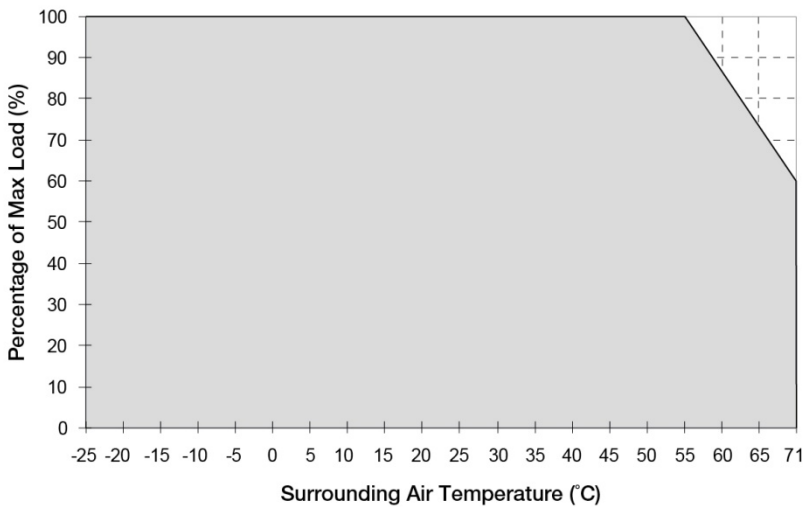

Fig. 1 De-rating for Vertical Mounting Orientation
 > 55°C de-rate power by 2.5% / °C

Note

1. Power supply components may degrade, or be damaged, when the power supply is continuously used outside the shaded region, refer to the graph shown in Fig. 1.
2. If the output capacity is not reduced when the surrounding air temperature exceeds its specification as defined on Page 3 under "Environment", the device may run into Over Temperature Protection. When activated, the output voltage will go into latch mode and recover when AC power recycles.
3. In order for the device to function in the manner intended, it is also necessary to keep a safety distance as recommended in the safety instructions while the device is in operation.
4. Depending on the surrounding air temperature and output load delivered by the power supply, the device can be very hot!
5. If the device has to be mounted in any other orientation, please contact info@deltapsu.com for more details.

Chrome DIN Rail Power Supply

24V 91.2W 1 Phase (Class II & NEC Class 2) / DRC-24V100W1A□

Output Load De-rating VS Input Voltage

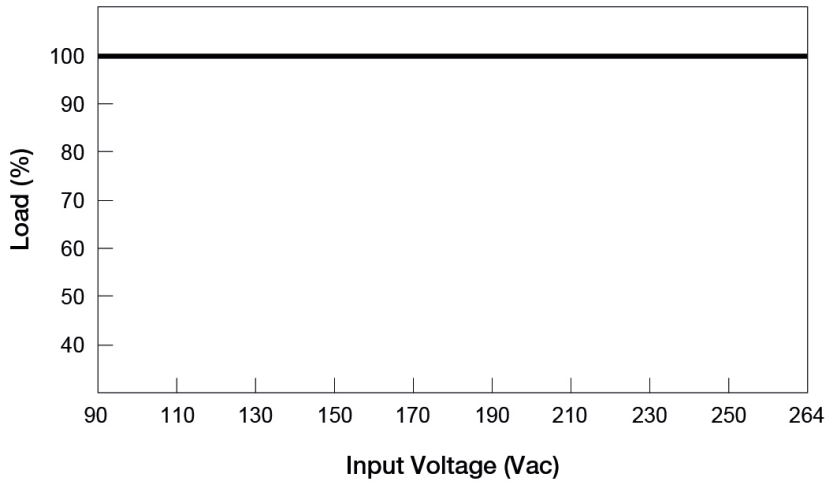

■ No output power de-rating across the entire input voltage range

Assembly & Installation

The power supply unit (PSU) can be mounted on 35 mm DIN rails in accordance with EN60715. The device should be installed with input terminal block at the bottom.

Each device is delivered ready to install.

Mounting

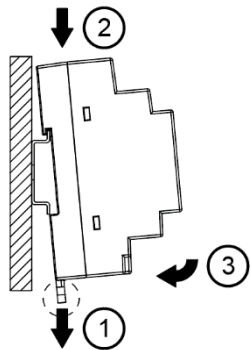

Fig. 2.1 Mounting

Snap on the DIN rail as shown in Fig. 2.1:

1. Pull the unit's DIN rail latch OUT.
2. Tilt the unit slightly upwards, hook the top end onto the DIN rail and push downwards until stopped.
3. Position the bottom front end against the DIN rail.
4. Push the unit's latch DIN rail IN to lock.

Dismounting

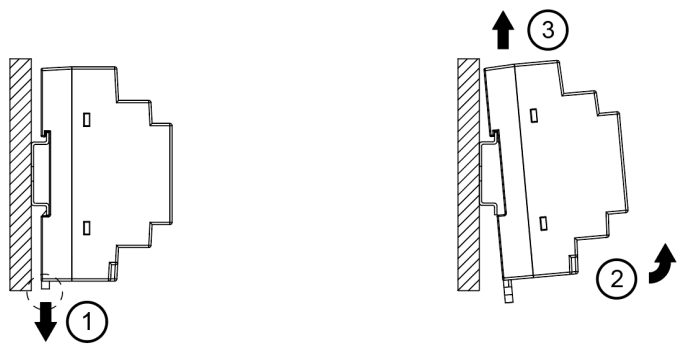

Fig. 2.2 Dismounting

To uninstall, pull the unit's DIN rail latch OUT as shown in Fig. 2.2. Tilt the bottom part of the unit out. Push the unit up and pull out from the DIN rail.

Chrome DIN Rail Power Supply

24V 91.2W 1 Phase (Class II & NEC Class 2) / DRC-24V100W1A □

Safety Instructions

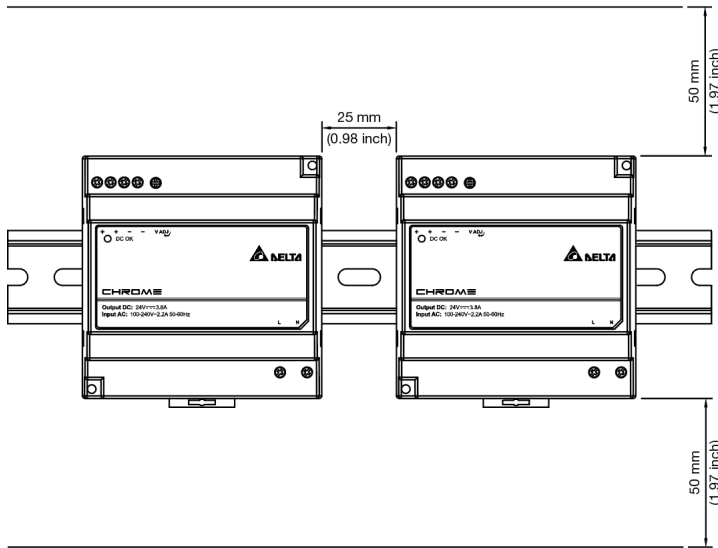

- ALWAYS switch mains of input power OFF before connecting and disconnecting the input voltage to the unit. If mains are not turned OFF, there is risk of explosion / severe damage.
- To guarantee sufficient convection cooling, keep a distance of 50 mm (1.97 inch) above and below the device as well as a lateral distance of 25 mm (0.98 inch) to other units.
- Note that the enclosure of the device can become very hot depending on the surrounding air temperature and load of the power supply. Risk of burns!
- DO NOT insert any objects into the unit.
- Hazardous voltages may be present for up to 5 minutes after the input mains voltage is disconnected. Do not touch the unit during this time.
- The power supplies are built in units and must be installed in a cabinet or room (condensation free environment and indoor location) that is relatively free of conductive contaminants.

Functions

■ Graph illustrating the Start-up Time, Rise Time, and Hold-up Time

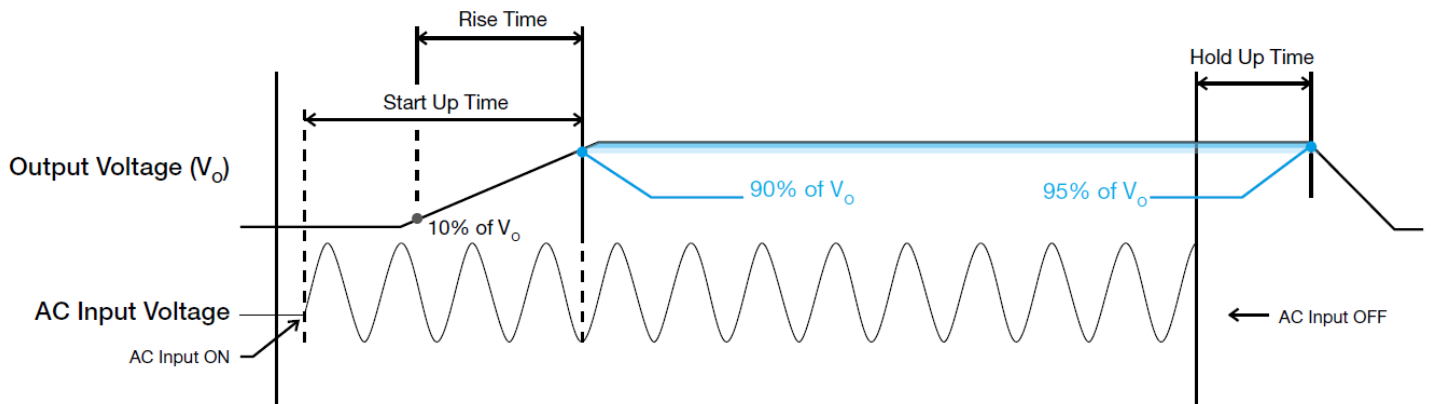

Start-up Time

The time required for the output voltage to reach 90% of its final steady state set value, after the input voltage is applied.

Rise Time

The time required for the output voltage to change from 10% to 90% of its final steady state set value.

Hold-up Time

Time between the collapse of the AC input voltage, and the output falling to 95% of its steady state set value.

Chrome DIN Rail Power Supply

24V 91.2W 1 Phase (Class II & NEC Class 2) / DRC-24V100W1A □

Inrush Current

Inrush current is the peak, instantaneous, input current measured and, occurs when the input voltage is first applied. For AC input voltages, the maximum peak value of inrush current will occur during the first half cycle of the applied AC voltage. This peak value decreases exponentially during subsequent cycles of AC voltage.

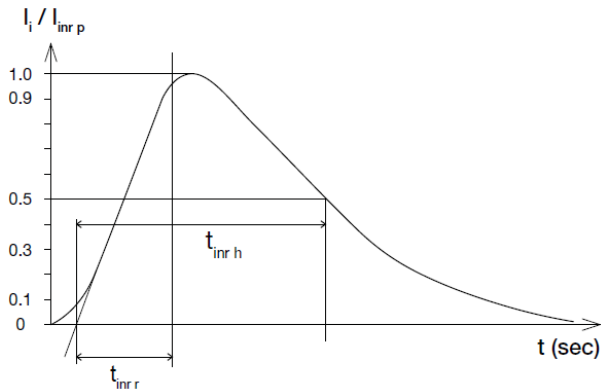

Dynamic Response

The power supply output voltage will remain within $\pm 5\%$ of its steady state value, when subjected to a dynamic load from 10% to 100% of its rated current.

- 50% duty cycle / 5 Hz to 100 Hz

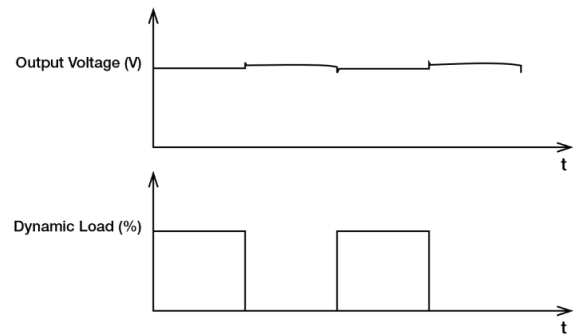

External Input Protection Device

The unit is protected with internal fuse (not replaceable) at L pin and it has been tested and approved on 20 A (UL) and 16 A (IEC) branch circuits without additional protection device. An external protection device is only required if the supplying branch has an ampacity greater than above. Thus, if an external protective device is necessary, or, utilized, a minimum value of 16 A B- or 8 A C- characteristic breaker should be used.

Chrome DIN Rail Power Supply

24V 91.2W 1 Phase (Class II & NEC Class 2) / DRC-24V100W1A □

Overload & Overcurrent Protections (Auto-Recovery)

The power supply's Overload (OLP) and Over current (OCP) Protections will be activated when output current is $3.8\text{ A} < I_o$ (Max load) $< 5.7\text{ A}$. In such occurrence, the output voltage (V_o) will start to droop and once the output voltage is below 13 Vdc typ., the power supply will go into "Hiccup mode" (Auto-Recovery). The power supply will recover once the fault condition of the OLP and OCP is removed and I_o is back within the specifications.

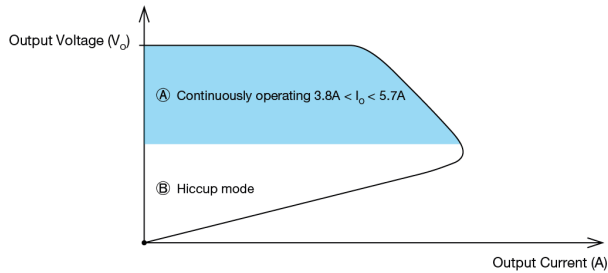

Additionally, if the I_o is $>102\sim 108\%$ for a prolonged period of time (depending on the load), the Over Temperature Protection (OTP) will be activated due to high temperature on critical components. The power supply will then go into "Latch mode" until the PSU cools down and the AC power is recycled.

Short Circuit Protection (Auto-Recovery)

The power supply's output OLP/OCP function also provides protection against short circuits. When a short circuit is applied, the output current will operate in "Hiccup mode", as shown in the illustration in the OLP/OCP section on this page. The power supply will return to normal operation after the short circuit is removed.

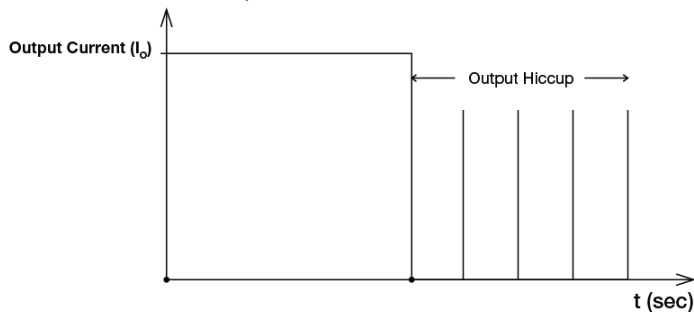

Overvoltage Protection (Latch Mode)

The power supply's overvoltage circuit will be activated when its internal feedback circuit fails. The output voltage shall not exceed its specifications defined on Page 3 under "Protections". Power supply will latch, and require removal/re-application of input AC voltage in order to restart.

The power supply should be latch.

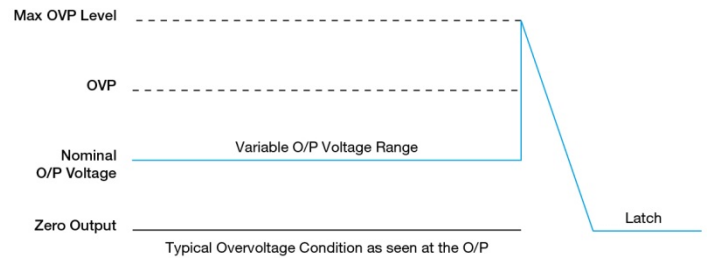

Over Temperature Protection (Latch Mode)

As described in load de-rating section, the power supply also has Over Temperature Protection (OTP). In the event of a higher operating temperature at 100% load; or, when the operating temperature is beyond what is recommended in the de-rating graph, the OTP circuit will be activated. When activated, power supply will latch, until the surrounding air temperature drops to its normal operating temperature or the load is reduced as recommended in the de-rating graph. Removal/re-application of input AC voltage will then be required in order to restart.

Chrome DIN Rail Power Supply

24V 91.2W 1 Phase (Class II & NEC Class 2) / DRC-24V100W1A □

Operating Mode

■ Redundant Operation

In order to ensure proper redundant operation for the power supply units (PSUs), the output voltage difference between the two units must be kept at 0.45~0.50 V for these 24 V supplies. Follow simple steps given below to set them up for the redundant operation:

Step 1.

Measure output voltage of PSU 1 and PSU 2. If PSU 1 is the master unit, then V_o of PSU 1 must be higher than PSU 2. In order to set the output voltage, individually connect each power supply to 50% of rated load at any line voltage, and set the PSU 1 and PSU 2 output voltage.

Step 2.

Connect the power supply units PSU 1 and PSU 2 to $V_{in 1}$ & $V_{in 2}$, respectively, of the DRR-20N (or 20 A) module shown on the right of above diagram.

Step 3.

Connect the system load to V_{out} . Please note that output voltage V_{out} from DRR module will be $= V_o$ (output voltage of power supply) $- V_{drop}^*$ (in DRR module).

* V_{drop} will vary from 0.60 V to 0.90 V (Typical 0.65 V) depending on the load current and surrounding air temperature.

■ Parallel Operation

The power supply units (PSUs) can also be used for parallel operation in order to increase the output power. The difference in output voltage between the two units must be kept to within 25 mV of each other. This difference must be verified with the same output load connected independently to each unit.

Parameters such as EMI, inrush current, leakage current, PARD, start up time will be different from those on the datasheet, when two units are connected in parallel. The user will need to verify that any differences will still allow the two power supplies connected in parallel will work properly in their product/application.

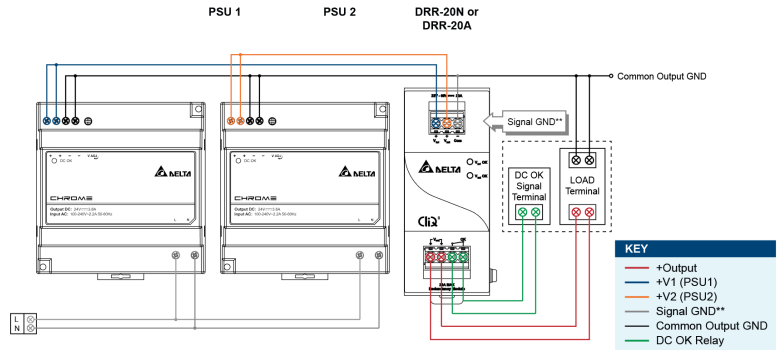

**The Signal GND in the DRR module is for the built-in LED and DC OK signals. The Output GND terminals from the two PSU's do not need to be connected to the Signal GND terminal.

Fig. 3 Redundant Operation Connection Diagram

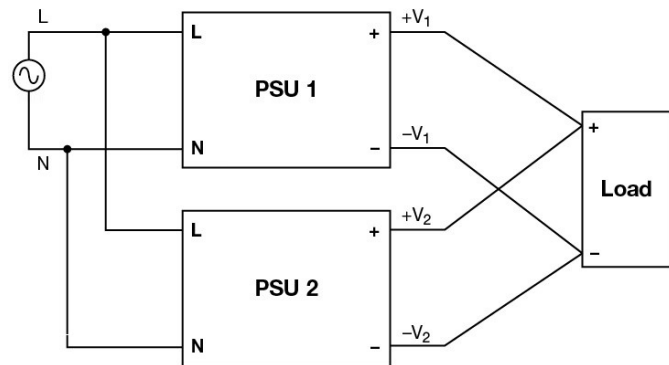

Fig. 4 Parallel Operation Connection Diagram

Chrome DIN Rail Power Supply

24V 91.2W 1 Phase (Class II & NEC Class 2) / DRC-24V100W1A □

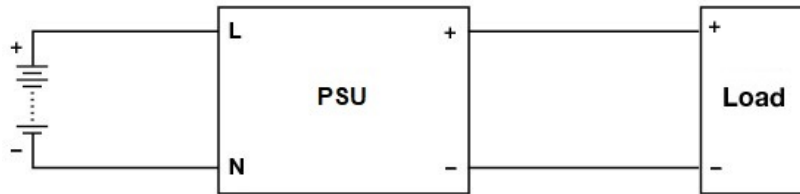

Fig. 5 DC Input Operation Connection Diagram

■ DC Input Operation

Step 1.
Use a battery or similar DC source.

Step 2.
Connect +pole to L and -pole to N.

Step 3.
Connect the PE terminal to an earth wire or to the machine ground.

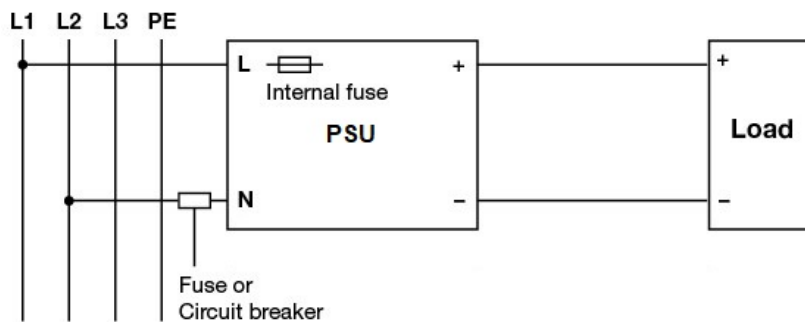

Fig. 6 2 of 3 Phase System Input Operation Connection Diagram

■ 2 of 3 Phase System Input Operation

Delta's Chrome can use on 2 of 3 phase system. Please refer to the following step.

Step 1.
The input voltage applied from Line to Neutral is below the maximum rated input. The input voltage shall be below 240 Vac +10%.

Step 2.
The external protector is needed on N (Neutral) input line to secure a safety. N line does not have internal fuse protection. An appropriate fuse or circuit breaker should be connected in series with N input line connection like the following.

Chrome DIN Rail Power Supply

24V 91.2W 1 Phase (Class II & NEC Class 2) / DRC-24V100W1A□

Others

PFC – Norm EN 61000-3-2

Line Current Harmonic content

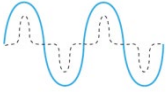

Typically, the input current waveform is not sinusoidal due to the periodical peak charging of the input capacitor. In industrial environment, complying with EN 61000-3-2 is only necessary under special conditions. Complying to this standard can have some technical drawbacks, such as lower efficiency as well as some commercial aspects such as higher purchasing costs. Frequently, the user does not profit from fulfilling this standard, therefore, it is important to know whether it is mandatory to meet this standard for a specific application.

Attention

Delta provides all information in the datasheets on an “AS IS” basis and does not offer any kind of warranty through the information for using the product. In the event of any discrepancy between the information in the catalog and datasheets, the datasheets shall prevail. Delta shall have no liability of indemnification for any claim or action arising from any error for the provided information in the datasheets. Customer shall take its responsibility for evaluation of using the product before placing an order with Delta.

Delta reserves the right to make changes to the information described in the datasheets without notice.