



*A clean image worth a thousand words.*

*Make your images worth more  
with the GV10x DS Asher*



# WHAT IS PLASMA PROCESSING?

## Downstream Plasma Technology for Cleaning TEM Samples on Carbon Films

Lianfeng Fu,<sup>1</sup> Haifeng Wang,<sup>1</sup> Christopher G. Morgan,<sup>2</sup> and Vincent Carlino<sup>2</sup>

<sup>1</sup>Western Digital Corporation, 44100 Osgood Road, Fremont, CA 94539  
<sup>2</sup>IBSS Group Inc., 1559B Sloat Blvd., Suite 270, San Francisco, CA 94132

### Introduction

With the advent of modern scanning/transmission electron microscopy (S/TEM) capable of higher resolution, better contrast, and faster throughput, it is imperative to ensure the cleanliness of the TEM sample under the ultrahigh vacuum conditions of the microscopes [1–5]. It is well known that sample contamination can severely deteriorate the quality of electron microscopy analysis of materials, especially as the sample regions of interest decrease in size. The adverse effects of sample contamination include obscuring the area of the sample being analyzed by buildup of a carbonaceous layer, interfering with focusing and astigmatism correction, and generating unexpected microanalysis signals [2, 3].

A variety of cleaning methods, including electron beam flooding, heating and/or cooling, ultraviolet light exposure, and plasma cleaning, have been developed to minimize sample contamination [4, 5]. Among them, plasma cleaning is considered the most effective way to prepare samples for electron microscopy. As shown in Figure 1a, a plasma can be described as an ionized gaseous state created by direct current (DC), radio frequency (RF), or microwave glow discharge, in which electrons, ions, and radicals coexist. The interaction of these plasma species with a solid surface causes three basic phenomena that lead to surface cleaning: heating from the electron-specimen interaction, sputtering from the ion-specimen interaction, and etching from the radical-specimen interaction [2]. Although the combination of all three plasma species is efficient in terms of cleaning rates, it can cause irreversible surface modification and undesirable heating. More problematically, as the plasma cleaning process removes the hydrocarbon contamination layer, it removes other carbon structures at the same time. This can be an issue for TEM carbon film users because the

carbon film is extensively used as a support on TEM grids for both materials science and biological applications. For example, our laboratory routinely loads from 10 to 50 ex-situ lifted-out TEM samples on a carbon film Cu-grid in order to support the high volume wafer-based manufacturing process [6]. If the carbon support film is damaged before the hydrocarbon contamination layer on the TEM samples is removed, valuable information in TEM samples will be lost. Therefore, it is essential to develop a method that removes only the hydrocarbon contamination layer while preserving the carbon support film.

Downstream oxygen plasma is one technology that has been extensively used in modern semiconductor and microelectronic manufacturing production lines as a dry ashing process [7, 8]. In the downstream oxygen plasma ashing process, the samples are not directly immersed in the glow discharge. Instead, they are positioned downstream or remote from the plasma source as shown in the Figure 1b. This is in contrast to the traditional plasma ashing process where the samples are directly immersed in the glow discharge and could suffer kinetic reactions with the accelerated ions and electrons from the plasma source.

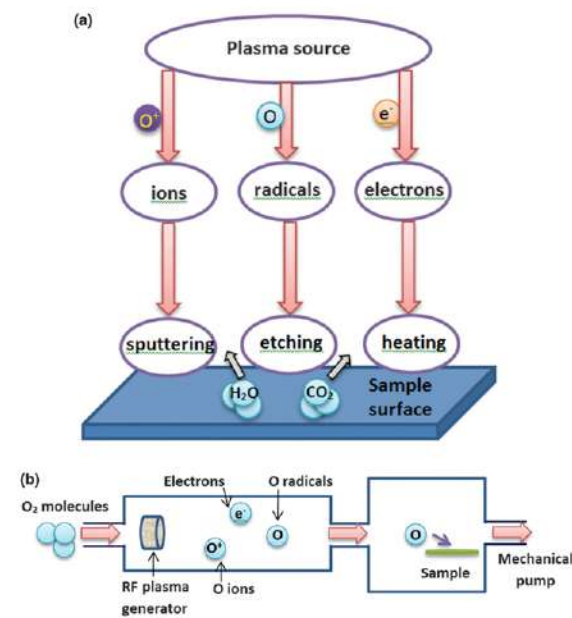

Figure 1: (a) Schematic representation of typical plasma cleaning mechanisms. (b) Schematic representation of a downstream plasma ashing system.

With this downstream setup, the plasma species, including ions, electrons, and radicals, are energetically relaxed and recombined upon arrival at the remotely positioned samples. Thus, only a large number of non-energetic radicals can reach the vacuum chamber and react with the sample surfaces for ashing. Because of the nature of radicals, the ashing process is relatively gentle and does not produce kinetic bombardment, sputter damage, or sample heating, unlike the traditional plasma ashing process.

Recently, IBSS Group Inc. has adopted this technology into the GV10x downstream plasma asher system for materials science and electron microscopy applications. This downstream plasma asher system can be used as an in-situ cleaner for scanning electron microscope (SEM) and focused ion beam (FIB) microscope chambers or can be customized into a portable system for TEM sample cleaning. In this work, we report the results of a systematic evaluation of the GV10x downstream plasma asher system in removing hydrocarbon contamination of TEM samples, primarily on holey carbon Cu-grids.

### Materials and Methods

Figure 2a shows the layout of the GV10x DS plasma asher system in our laboratory. It is mainly composed of three components: plasma asher source, vacuum chamber, and RF controller. The plasma asher source is mounted to the vacuum chamber directly. In this way, no obstruction is introduced into the downstream flow of the source so that the highest cleaning efficiency can be achieved.

The ashing gas can be room air or a mixture of Ar and O<sub>2</sub> gases. In our case, we use clean dry air (CDA) in order to avoid the impact of moisture variation. The GV10x asher source is fitted with a variable constriction valve to accommodate a large operating pressure range from 2.0 Torr to below 0.4 mTorr. The operating pressure depends on the speed of the vacuum pumps used to evacuate the chamber and the throughput of the vacuum valve. When the GV10x source is mounted on a turbo molecular-pumped SEM or dual-beam FIB chamber, the base chamber pressure can be < 0.4 mTorr. With a dry vacuum pump (scroll pump), the

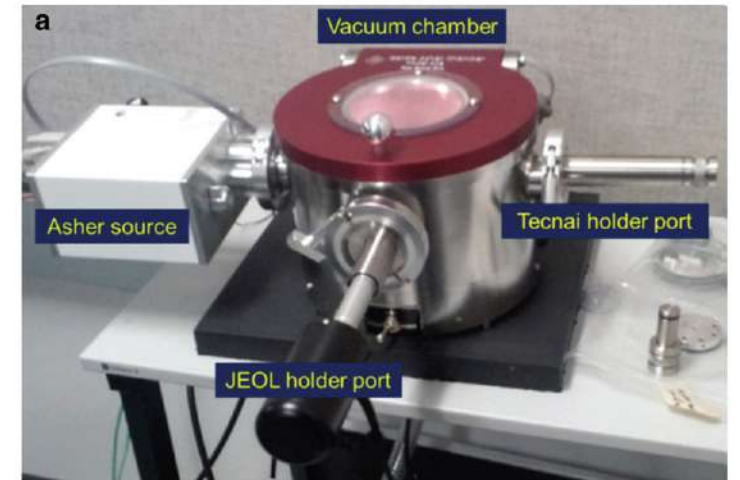

Figure 2: (a) Assembly of the GV10x downstream plasma Gentle Asher system showing the downstream plasma asher source, vacuum chamber, and two TEM holder ports. (b) GV10x controller panel showing the user interface and buttons.

base pressure ranges between 50 mTorr and 500 mTorr. The vacuum chamber can be fitted with two different TEM holder ports simultaneously, for example, an FEI holder port and a JEOL holder port. The position of the port ensures that the sample for cleaning is immersed right at the center of the vacuum chamber and along the downstream flow direction of the source. Figure 2b shows the RF source control panel and its user interface. The operating parameter screen allows the user to set the operating parameters such as ignition plasma power, actual work power, and run time by using the up/down or increase/decrease buttons. Our laboratory uses the factory-recommended power at 50

# HOW EFFECTIVE IS THE GV10x?

## Downstream Plasma Technology for Cleaning TEM Samples on Carbon Films

watts, although the power can be adjusted to values between 10 and 99 watts.

TEM/STEM imaging, energy dispersive X-ray (EDX), and electron energy loss spectroscopy (EELS) analyses were carried out on a 200 kV Schottky field-emission gun (FEG) FEI Tecnai F20 ST microscope. This microscope is fully loaded with an analytical pole-piece objective lens, an EDAX X-ray detector, and a Tridiem Gatan image filter (GIF) spectrometer. The energy resolution for low-loss EELS spectra is typically 0.90 eV. Each EELS spectrum was corrected for dark current and spectrometer gain variations.

### Results

Cleaning the carbon film itself. Before we evaluate the hydrocarbon contamination cleaning effect, it is worthwhile to study the impact of downstream plasma ashing on the holey carbon film alone. A primary reason is that tens of our TEM samples are loaded on the holey carbon film grid as mentioned earlier. We do not want to take the risk of losing TEM samples if the carbon film breaks while being cleaned. In order to find out the safe time window when the holey carbon film can still survive during downstream plasma ashing, we have applied a multi-step scheme in the design of the experiment.

In this scheme we first load the blank holey carbon film Cu grid in the microscope and take an image as reference. Then, we take out the grid, plasma ash it with a certain time, and reload it in the microscope. Thus, the downstream plasma ashing time we state is a cumulative time. Figures 3a to 3b show a series of images of holey carbon film supported Cu-grid with this multi-step scheme. As can be seen in the images, the contrast of the holey carbon film decreases with the increasing time. This indicates the thickness of holey carbon film may be decreasing with increasing downstream plasma ashing time. At the longest downstream plasma ashing time of 720 s, the holey carbon film barely shows contrast, and some film areas become ruptured. At this situation, we consider

the holey carbon film unusable.

We did a similar experiment with the traditional plasma cleaner, and the holey carbon film break-up time was less than 20 s. Thus, the downstream plasma ashing system shows an obvious improvement compared to the traditional one. This also supports the gentle ashing mechanism of radicals mentioned earlier.

**Carbon film thickness changes.** In order to validate the thickness change of holey carbon film during the downstream plasma ashing process, we used EELS analysis. It is well established that EELS can provide quick and reliable measurement of local thickness from both crystalline and amorphous samples. Sample thickness can be calculated by straightforward integration of the low-loss EELS spectrum with the following formula [9]:

$$t = \lambda \times \ln(IT/I_0) \quad (1)$$

where  $t$  is the sample thickness,  $\lambda$  is the characteristic mean free path of inelastic scattering for the material,  $IT$  is the total integrated intensity of electrons in the EELS spectrum, and  $I_0$  is the intensity of electrons having lost no energy, namely the zero-loss peak (ZLP). Figure 4a shows the relative changes of the low-loss EELS spectra of holey carbon film before and after plasma ashing treatment. Here all the spectra have been vertically normalized according to their ZLP heights (ZLP not shown in the plot). The peaks next to ZLP are plasmon peaks. Plasmons are collective oscillations of specimen valence electrons, and their energy loss is usually in the range 10–40 eV.

When the TEM sample thickness is thin, for example, less than 30 nm, we can assume the only significant scatter event is a single plasmon event. Thus, the formula above can be modified into a simpler expression:

$$t = \lambda_p \times \ln(I_p/I_0) \quad (2)$$

where  $\lambda_p$  is the characteristic plasmon mean free path, and  $I_p$  is the integrated intensity of plasmon peak in the EELS spectrum.

According to this new formula, the intensity change of plasmon peak can directly reflect the thickness change for each spectrum as we normalize ZLP for all the spectra in the Figure 4a. Thus we can say the holey carbon film becomes thinner after downstream plasma ashing treatment by just looking at the decreasing plasmon peak intensity.

More quantitatively, we have adopted the log-ratio technique, which is embedded in the Gatan DigitalMicrograph (DM) program and is based on Equation 1, to calculate the thickness of the holey carbon film. Figure 4b shows the calculated thickness change of holey carbon film plotted as a function of downstream plasma ashing time. This shows that the holey carbon film thickness decreases with the increasing downstream plasma ashing time. The data points are collected from the film area in the same grid opening. The as-received holey carbon film thickness is calculated to be  $27 \text{ nm} \pm 3 \text{ nm}$ , which is consistent with what the grid supplier claims. The last data point is collected after the film is downstream plasma-ashed for 720 s. At this condition, the carbon film is close to

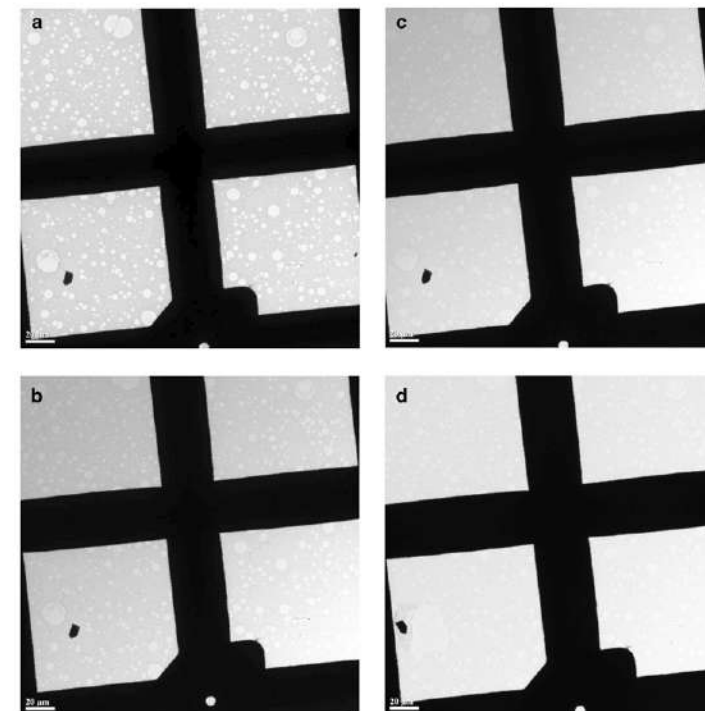

Figure 3: Images of holey carbon film supported Cu-grid before and after downstream plasma ashing: (a) 0s, (b) 240s, (c) 480s, (d) 720s.

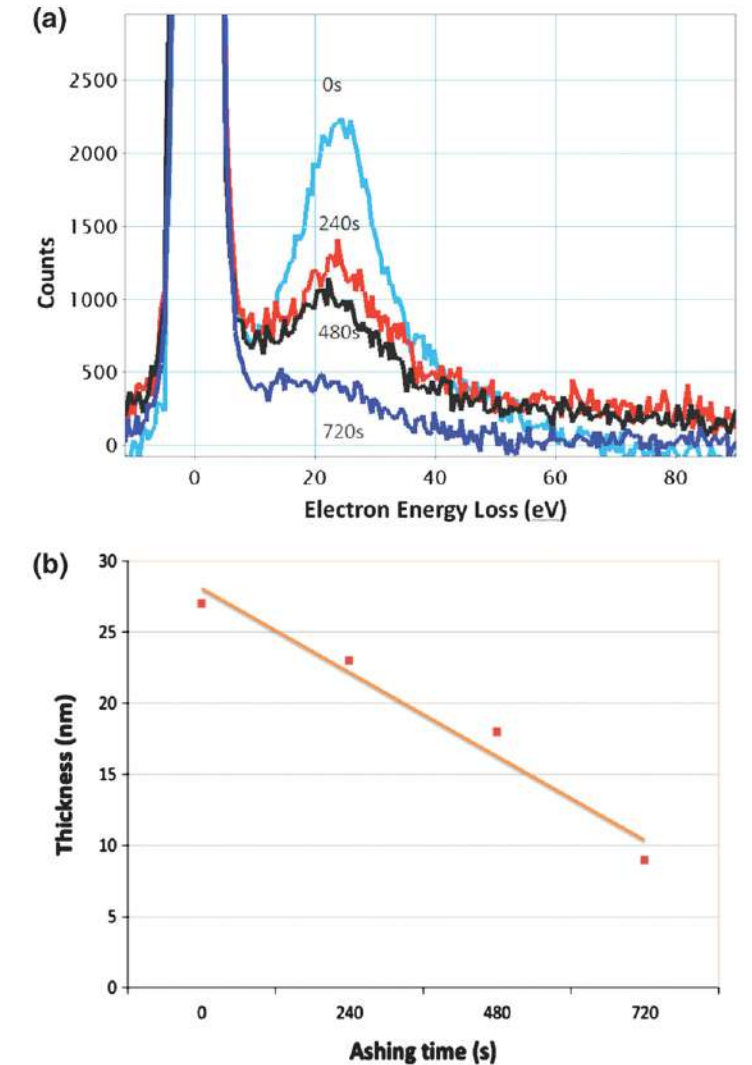

Figure 4: (a) Low-loss EELS of holey carbon support film before and after downstream plasma ashing treatment. (b) Thickness of holey carbon support film as a function of downstream plasma ashing time.

break-up; therefore, the thickness measurement is ambiguous because some film areas are already ruptured.

Luckily, the film area we selected for data collection was still intact. The holey carbon thickness we measured for the 720 s ashing was  $9 \text{ nm} \pm 3 \text{ nm}$ . At such a thin thickness, the holey carbon film is very fragile and probably at a critical point. Thus, any internal stress or even an air pressure fluctuation during sample loading and unloading could be sufficient to rupture the film.

# "ESSENTIAL STEP IN MODERN ANALYTICAL ELECTRON MICROSCOPY"

## Downstream Plasma Technology for Cleaning TEM Samples on Carbon Films

Based on these data points, we calculate the etching rate of holey carbon film during downstream plasma ashing treatment as about 1.5 nm/min. This can be a good reference for our routine downstream plasma ashing procedure. Once we have the film thickness value for any as-received holey carbon film, we may estimate the safe ashing time window based on the etching rate.

**Specimen cleaning efficiency.** Next, it is necessary to evaluate if the GV10x DS Asher can effectively clean the hydrocarbon contamination on the TEM sample. Figure 5a shows the STEM image from a typically contaminated sample loaded on a holey carbon support film Cu-grid. It shows signs of significant contamination under the electron beam as marked by an arrow.

The contamination mark grew quickly after electron beam was placed on the region of interest. After only a 60 s exposure, nearly half of the field of view was covered by the contamination mark, and its size extended up to 300 nm. In order to understand the source of the contamination, we used EDX microanalysis to analyze the contamination mark. A typical EDX spectrum of the contamination mark is shown as unfilled purple in Figure 5b. As determined from the spectrum, there are significant X-ray signals from foreign elements Si, C, and O, besides the as-designed shield materials Ni<sub>x</sub>Fe<sub>1-x</sub>, detected on the contamination mark. The C and O contamination species are understandable because oxygen atoms could cross-link with carbon species and form carbon monoxide and a hydrocarbon layer on the sample surface [7]. However, the strong signal of Si was not expected. We confirmed it by multiple analyses.

As far as the experiment goes, we would like to know if the plasma asher system can effectively clean all the contamination species. Because the TEM sample is loaded on a holey carbon support film, we may use the previously determined safe time window as a guide to design the experiment for the downstream plasma

ashing experiment. We decided to use 120 s as an interval to test downstream plasma ashing clean efficiency. The filled blue plot in Figure 5b is the EDX spectrum from a fresh area after the sample was downstream plasma-ashed for 120 s. We see from this comparison that the contamination species C and O were significantly decreased compared to the pre-treatment. The unexpected contamination species Si peak is also greatly reduced from 800 counts to 50 counts

Figure 6 shows that all the three contamination species decrease drastically after the sample was ashed for 120 s. Longer clean times could further reduce the concentration of contamination species but not as obviously as in the first 120 s.

### Discussion

The effective ashing time of 120 s is much shorter than the time of 720 s for breakup of the holey carbon support film. This means that the TEM sample on the holey carbon support film is safe to be cleaned in such a downstream asher system. More importantly, the sample can be cleaned multiple times. This is useful for the case when the treated TEM samples are stored over a long time and the sample contamination appears again.

### Conclusion

Plasma cleaning has become an essential step in modern analytical electron microscopy, which requires contamination-free samples for imaging and elemental analysis. However, the dilemma for carbon film TEM grid users is how to plasma-clean the hydrocarbon contamination while preserving the carbon support film. In order to solve this problem, we have evaluated a new downstream plasma asher system, which uses a gentle and non-kinetic clean mechanism to minimize the side effects of plasma-sample interactions. The results show the system can effectively remove the contamination while preserving the carbon support film. A safe time window and a rule-of-thumb cleaning recipe for this system are suggested.

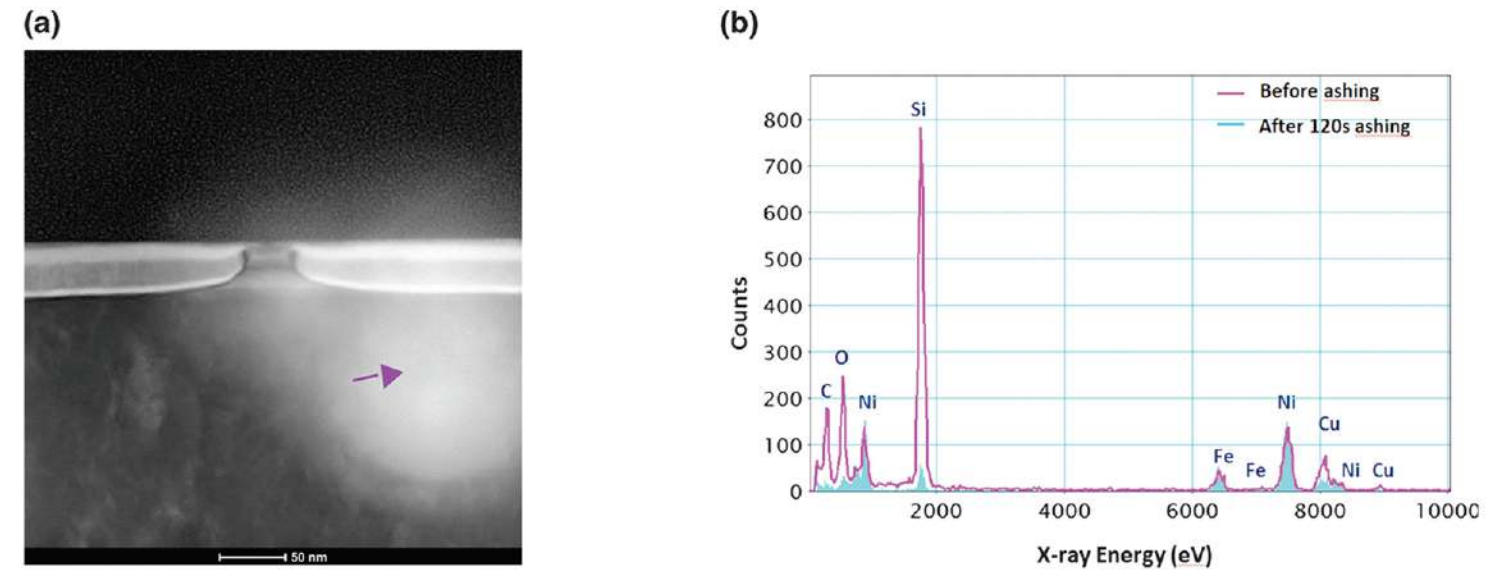

Figure 5: (a) Typical STEM image of a heavily contaminated sample showing the deteriorative effect of carbonaceous contamination build-up. (b) Comparison of EDX spectra on the NiFe magnetic shield material before and after 120 s downstream plasma ashing. Note that each spectrum is acquired from a fresh area.

*"Based on these data points, we calculate the etching rate of holey carbon film during downstream plasma ashing treatment as about 1.5 nm/min."*

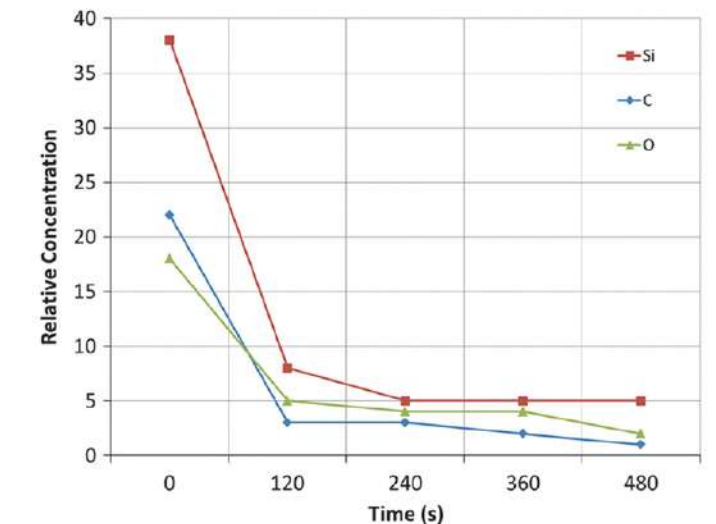

Figure 6: Plots of the contamination species (Si, C, O) as a function of time before and after downstream plasma ashing treatment.

### References

- [1] LF Fu, SJ Welz, ND Browning, M Kurasawa, and PC McIntyre, Appl Phys Lett 87(26) (2005) 262904–06.
- [2] JT Grant, SD Walck, FJ Scheltens, and AA Voevodin, Mat Res Soc Symp Proc 480 (1997) 49–71.
- [3] C Soong, P Woo, and D Hoyle, Microscopy Today 20(6) (2012) 44–48.
- [4] TC Isabell, PE Fischione, C O’Keefe, MU Guruz, and VP Dravid, Microsc Microanal 5 (1999) 126–35.
- [5] SP Roberts, NJ Zaluzec, SD Walck, and JT Grant, Mat Res Soc Symp Proc 480 (1997) 127–36.

- [6] H Wang, J Fang, J Arjavac, and R Kellner, Microscopy Today 16(1) (2008) 24–27.
- [7] HG Tompkins and JA Sellers, J Vac Sci Technol A 12(4) (1994) 2446–50.
- [8] GJ Gorin, U.S. Patents US6263831B1, 2001, US6112696A, 2000, US7015415B2, 2006.
- [9] DB Williams and CB Carter, Transmission Electron Microscopy: A Textbook for Materials Science, Springer, New York, 2009.

# GV10x™

## PLASMA CLEANER

The GV10x Downstream Plasma Asher process of producing plasma at low pressure is proven to be an inspired improvement beyond the traditional methods of mitigating contamination using cold trapping, nitrogen purging, and other type plasma cleaners.

The GV10x, with its extended operating parameters: power, up to 100 Watts, and pressure 2 to <math>0.5 \text{ E-3 Torr}</math> represents a paradigm shift of carbon mitigation in SEM, FIBs and other vacuum chambers where low carbon levels are required.

Plasmas of atomic oxygen and atomic hydrogen oxidize or reduce hydrocarbon contamination by converting surface carbons into gas phase molecules which are pumped out of chambers not just immobilized on trapping surfaces. Sample artefacts from polymerized deposits are minimized by low carbon levels in SEM chambers.

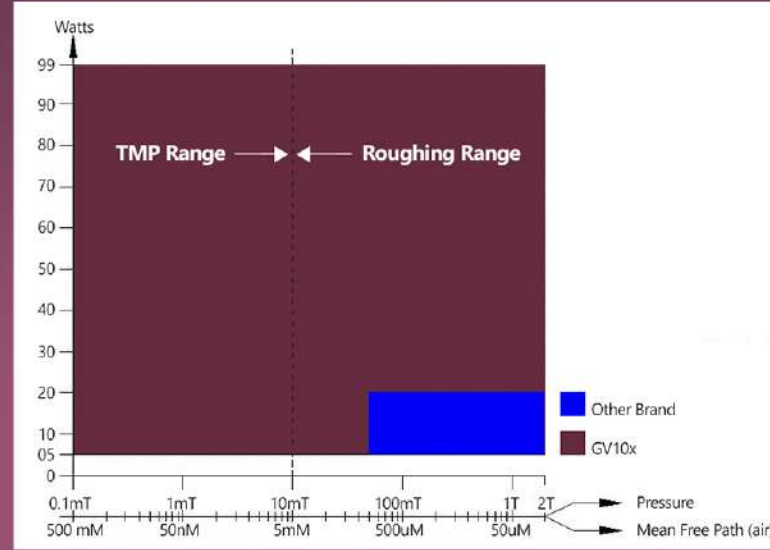

Turns Open	60 l/m Scroll Chamber volume 189 in <sup>3</sup>	Plasma ignited	71 l/s TMP Chamber Volume 189 in <sup>3</sup>	Plasma ignited	304 l/s Chamber Volume 2004 in <sup>3</sup>	Plasma ignited
Variable Constriction	Chamber Pirani Pressure		Chamber Pirani Pressure		Chamber Pirani Pressure	
0	67 milliTorr	yes	2.8E-5 Torr	no	1.0E-5 Torr	no
1	67 milliTorr	yes	8.9E-5 Torr	no	1.0E-5 Torr	no
2	67 milliTorr	yes	3.6E-4 Torr	yes	1.0E-5 Torr	no
3	67 milliTorr	yes	6.9E-4 Torr	yes	1.0E-5 Torr	no
4	83 milliTorr	yes	2.2 milliTorr	yes	1.0E-5 Torr	no
5	130 milliTorr	yes	5.8 milliTorr	yes	5.0E-4 Torr	no
5 1/2	170 milliTorr	yes	9.0 milliTorr	yes	7.0E-4 Torr	yes
6	210 milliTorr	yes	12 milliTorr	yes	8.0E-4 Torr	yes
6 1/2	260 milliTorr	yes	14 milliTorr	yes	8.0E-4 Torr	yes
7	310 milliTorr	yes	18 milliTorr	yes	1.0 milliTorr	yes
7 1/2	370 milliTorr	yes	24 milliTorr	yes	3.0 milliTorr	yes
8	450 milliTorr	yes	31 milliTorr	yes	5.0 milliTorr	yes
8 1/2	520 milliTorr	yes	40 milliTorr	yes	6.0 milliTorr	yes
9	590 milliTorr	yes	52 milliTorr	yes	7.0 milliTorr	yes
9 1/2	660 milliTorr	yes	70 milliTorr	yes	7.0 milliTorr	yes
10	720 milliTorr	yes				
10 1/2	810 milliTorr	yes				

Grey boxes = Ideal operating range



## SCAN SQUARE ON WAFER

Infamous contamination rectangles are caused by polymerized HC 'schmutz' that accumulates on samples. The deposits on these dirty wafers were caused by scanning 10 minutes at 1.2kV.

The ibss GV10x cleaner removed nearly all contamination build-up from the wafer surface after a total clean time of 13 minutes. It was noted that the line-widths before cleaning were significantly larger from the contamination build-up, but reduced back to the original line width after cleaning

The ibss GV10x cleaner cleaned the surface of the wafer (prior to imaging) and did not show signs of contamination build-up post cleaning.

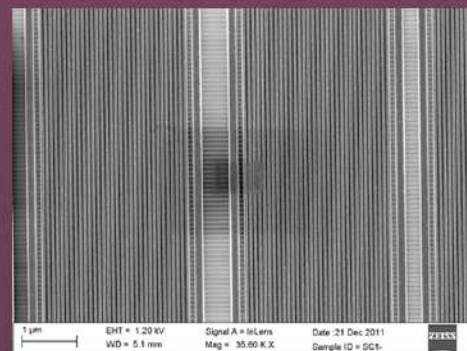

BEFORE :  
Imaging Conditions:  
- 1.2kV Accelerating Voltage  
- 10 minutes scan time  
- Chamber Pressure: 6.08-10-6 Torr

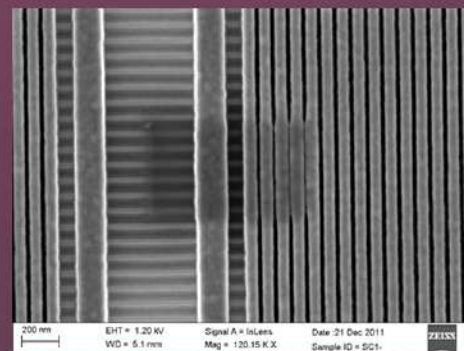

AFTER :  
Imaging Conditions:  
- 1.2kV Accelerating Voltage  
- Chamber Pressure: 6.08-10-6 Torr  
Cleaning Conditions:  
- Chamber Pressure: 7.53-10-4 Torr  
- Power: 45 Watt  
- Duration: 8 minutes (3mins plus 5mins)

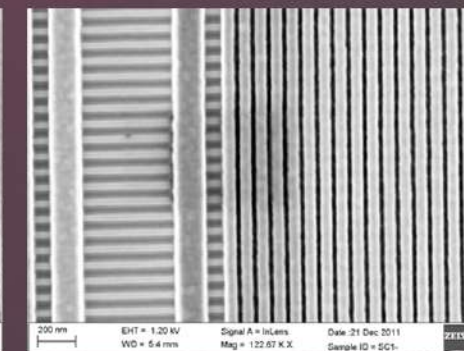
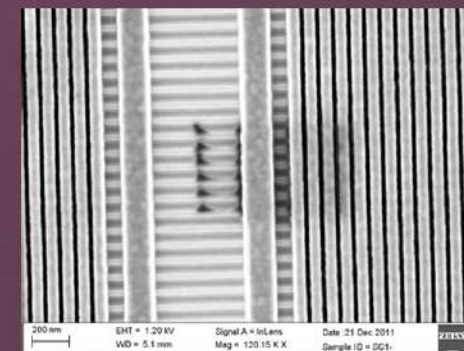

AFTER :  
Imaging Conditions:  
- 1.2kV Accelerating Voltage  
- Chamber Pressure: 6.08-10-6 Torr  
Cleaning Conditions:  
- Chamber Pressure: 7.32-10-4 Torr  
- Power: 50 Watts  
- 13 minutes (total clean time)

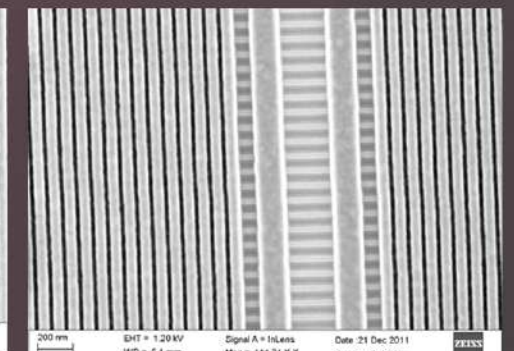

AFTER : Adjacent Area Scans  
Imaging Conditions:  
- 1.2kV Accelerating Voltage  
Note:  
After a total clean time of 13 minutes, no contamination was visible after scanning for 10 minutes

# GVGA™

## GV10x Gentle Asher

Clean specimens prevent high resolution imaging degradation and additional SEM & TEM chamber contamination build up in the gas phase and on internal microscope surfaces.

Gentle Asher, GV/GA, is tabletop ex-situ plasma cleaning station with a high vacuum stainless steel chamber for SEM sample and TEM holder cleaning and storage.

Minimize hydrocarbon contamination accumulation in EM chambers by precleaning samples before EM insertion. Specimens can be gently cleaned by oxidation and reduction with oxygen and hydrogen gas mixtures without damage to specimen topography.

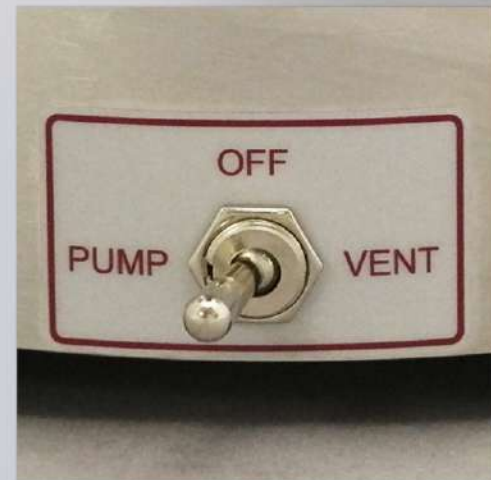
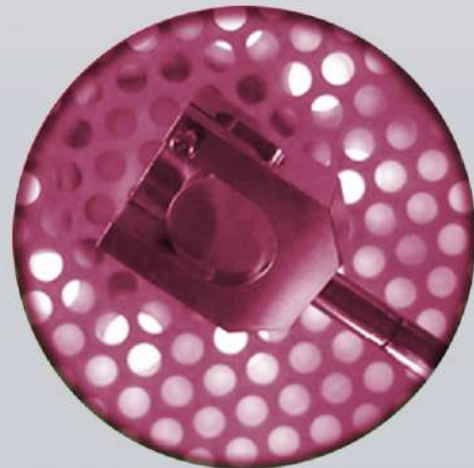

# MCA™

## Mobile Cubic Asher

Mobile Cubic Asher, MCA, is an all-inclusive, plug & play ex-situ and in-situ mobile station for EM sample and chamber cleaning.

SEM and TEM specimens inserted into the MCA are cleaned by gentle oxygen ashing of surface contamination without introducing artefacts onto specimen topography. After cleaning, samples can be stored under vacuum until the next step in user's process.

Mobile capabilities provide an ideal platform for contamination control in laboratories with one or more electron microscopes. The P5 Qwk-Switch™ source with bayonet fitting can easily shift to multiple EM chambers to minimize hydrocarbon contamination.



Qwk-Switch Source



Chamber



Up to 3 TEM Holder Ports



Touch Screen



3-Way Toggle Switch



Dry Scroll Pump  
Gas Cylinder (Optional)

For specific application, user may request drop ship of needed gas mixture



Controller



# CHIARO™

High Vacuum Mobile Plasma Asher



The Chiaro, ibss Group's latest model of mobile asher.

Combines with several specimen preparation requirements into one easy to use mobile laboratory station. Plasma cleaning of TEM Holders and SEM specimens at the SEM & TEM site with Qwk-Switch™ plasma cleaning SEM chambers are standard features:

- Plasma cleaning liquid and gas cell surfaces
- Making liquid cell surfaces hydrophilic
- Testing liquid and gas cell vacuum integrity at HV pressure
- Mounting and viewing TEM samples at 40X during all processes
- Oxidative and or reductive hydrocarbon cleaning of metallic or organic samples
- TEM holder cleaning and storage
- Toggle switch control with digital data entry, parameter setting, menu memory

# GV10x™

## SYNCHROTRON APPLICATION

“Synchrotron radiation has become a powerful tool around the world. The increase of synchrotron laboratories highlights the interest by commercial, educational and medical science research for the analytical results possible with high-intensity light sources.

New generation synchrotron sources with enhanced performance such as free electron lasers (FEL) open new possibilities for fundamental and applied research. However a pressing requirement is to maintain the enhanced performance of these reflective and transmission beamline optics. By eliminating the carbon contamination from these optics and transmission filters. Carbon deposits are thought to be produced by cracking of CH<sub>x</sub> and CO<sub>2</sub> residual gas molecules from photoelectrons emitted from the optical components. The deposition phenomena is rather complex depending on the specific case because Carbon molecules do not just consist of one single carbon allotrope but may also contain contributions from sp<sup>2</sup> and sp<sup>3</sup> hybridized carbon species.

The contamination seriously impedes high-performance beam lines by the reductions of photon flux, beam coherence, destructive interference and scattering losses. Previous publications [1-7] unless you show the reference as footnote I would skip this ref. have shown that it is possible to clean carbon contaminations in a safe and efficient way using an ICP, Inductively coupled plasma with different results from gas mixtures.

Oxygen and hydrogen plasmas gas mixtures are advantageous to clean carbon contaminations in that they activate a molecular gas by dissociation and chemical cleaning which unlike physical sputtering consists of the formation of volatile molecules on the target surface due to chemical reactions with incident chemically active species onto the surface.”

- Moreno Fernandez, Harold Anibal Ph. D.



## CARBON ON Al FILTER

Using the GV10x chemical neutral plasma processing, carbon was removed from a 100 nm thick Al filter.

RF Power: 100W  
Duration: 110 minutes



Before | Al- 100nm filter (front)



Before | Al- 100nm filter (front)  
At an gle, wrinkles can be seen



Before | Al- 100nm filter (back)



After | Al- 100nm filter (front)  
The wrinkles and contamination are eliminated



After | Al- 100nm filter (back)

## GV10x Downstream Plasma Asher

### P5<sup>1</sup> Source Specifications



P540 / P5QS Sources

<b>Power (Watts)</b>	10 to 99
<b>Pressure</b>	2.0 Torr to <5 mTorr pressure
<b>Shutoff leakage rate</b>	1E-8 Torr l/s, 1.3E-9 Pa-m <sup>3</sup> /s.
<b>Plasma Driving Gas</b>	Air, CDA, other gases or gas mixtures
<b>Fitting</b>	KF25, KF40 or Qwk-Switch™
<b>Dimensions H x W x D</b>	4.1 x 3.1 x 7.2 in.
	104 x 79 x 183 mm
<b>Weight</b>	3 lbs. / 1.4 kg

### GV10x Controller Specifications



2U / Benchtop Controllers

	Benchtop	2U Rackmount
<b>Dimensions H x W x D</b>	6.81 x 8.2 x 17.25 in.	3.5 x 17 x 4.7 in.
	173 x 209 x 439 mm	89 x 432 x 374 mm
<b>Weight</b>	16 lbs. / 7.3 kg	17 lbs / 7.7 kg
<b>Digital Interface</b>	Yes	Yes
<b>PC Operation</b>	Opto-isolated COM Port for Windows OS	Opto-isolated COM Port for Windows OS
<b>Software</b>	GV10x Remote Control	GV10x Remote Control
<b>Power Supply</b>	100-230 VAC 50/60 Hz, 13.56 MHz RF	100-230 VAC 50/60 Hz, 13.56 MHz RF
	Power consumption 500VA, Impedance 50 Ohms	Power consumption 500VA, Impedance 50 Ohms

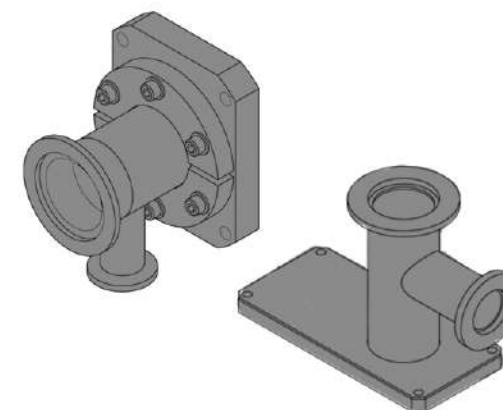

### Spooler

To mount the GV10x Asher Source onto SEM, TEM, FIB or other analytical instrument port, an adapter, called spooler, will be provided.

Customer must inform correct port dimensions and o-ring groove dimensions for the proper spooler to be supplied. A port location slightly above or in line with the sample stage is recommended.

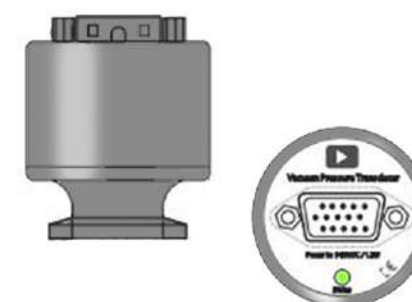

### MicroPirani Pressure Gauge

MicroPirani, a gauge that provides pressure reading at the plasma source.

With a range of 1x10<sup>-5</sup> Torr to atmosphere, the pirani reading provides the user an easy way to adjust the optimum pressure for plasma ignition.

On load locks or the MCA chamber the MicroPirani offers auto plasma ignition at specified pressure with the 'pressure trigger' function.

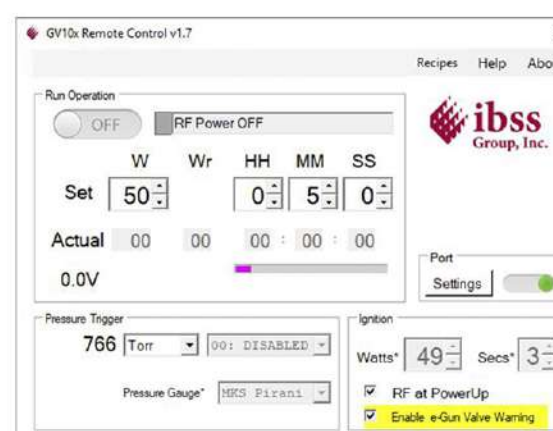

### GV10x Remote Control Software

ibss software provides user-friendly interface with various features.

- Compatible with Windows-based PC or Tablet
- Electron Gun Valve Warning
- Set cleaning Watts & Duration
- Set and monitor operating power during a run and pressure is selectable from the Source Variable Constriction.
- Wide operating pressure range allows hydrocarbon removal at full TMP rotation without danger or interruption of system interlock software.
- Pressure Trigger: enables plasma ignition when Source pirani pressure reaches a selectable pressure.

### PN# GV10x DS Asher

**P5C** Patented plasma Source & 1 ea. Spooler  
Variable Constriction, 0.5 µm inlet gas filter  
Controller & Cable bundle, MicroPirani  
Interactive GUI & Software

### GV10x for more than 1 SEM

**PQC** Item A w/ Qwk-Switch Plasma Source

**QS4T** Qwk-Switch Adapter w/ plug, 1 per SEM

**SP** Additional Spooler

<sup>1</sup>GV10x DS Asher comprised of a patented Plasma Source and Controller  
Contact ibss Group for hydrogen cleaning

Prices: FOB Burlingame, CA  
Terms: Net 30 Days  
Delivery: 8 weeks ARO  
Warranty: Three Year Limited



## GV10x Downstream Plasma Asher w/ Conflat



P3CF Source

P3CF <sup>1</sup> Source	
Power (Watts)	10 to 99
Pressure	2.0 Torr to <5 mTorr pressure
Shutoff leakage rate	1E-8 Torr l/s, 1.3E-9 Pa-m <sup>3</sup> /s.
Plasma Driving Gas	Air, CDA, other gases or gas mixtures
Fitting	ConFlat
Dimensions H x W x D	6.2 x 3.1 x 9.51 in.
	158 x 79 x 242 mm
Weight	6 lbs. / 2.7 kg



2U / Benchtop Controllers

Controller		
	Benchtop	2U Rackmount
Dimensions H x W x D	6.81 x 8.2 x 17.25 in.	3.5 x 17 x 4.7 in.
	173 x 209 x 439 mm	89 x 432 x 374 mm
Weight	16 lbs. / 7.3 kg	17 lbs / 7.7 kg
Digital Interface	Yes	Yes
PC Operation	Opto-isolated COM Port for Windows OS	Opto-isolated COM Port for Windows OS
Software	GV10x Remote Control	GV10x Remote Control
	100-230 VAC 50/60 Hz, 13.56 MHz RF	100-230 VAC 50/60 Hz, 13.56 MHz RF
Power Supply	Power consumption 500VA, Impedance 50 Ohms	Power consumption 500VA, Impedance 50 Ohms

PN #	GV10x DS Asher
P3CF	Patented plasma Source Variable Constriction, 3 µm inlet gas filter Controller & Cable bundle, MicroPirani Interactive GUI & Software

<sup>1</sup>GV10x DS Asher comprised of a patented Plasma Source and Controller  
Contact ibss Group for hydrogen cleaning

Prices: FOB Burlingame, CA  
Terms: Net 30 Days  
Delivery: 8 weeks ARO  
Warranty: Two Year Limited



## GV/GA



P540 / P5QS Sources

P5 <sup>1</sup> Source	
Power (Watts)	10 to 99
Pressure	2.0 Torr to <5 mTorr pressure
Shutoff leakage rate	1E-8 Torr l/s, 1.3E-9 Pa-m <sup>3</sup> /s.
Plasma Driving Gas	Air, CDA, other gases or gas mixtures
Fitting	KF25, KF40 or Qwk-Switch™
Dimensions H x W x D	4.1 x 3.1 x 7.2 in.
	104 x 79 x 183 mm
Weight	3 lbs. / 1.4 kg



2U / Benchtop Controllers

Controller		
	Benchtop	2U Rackmount
Dimensions H x W x D	6.81 x 8.2 x 17.25 in.	3.5 x 17 x 4.7 in.
	173 x 209 x 439 mm	89 x 432 x 374 mm
Weight	16 lbs. / 7.3 kg	17 lbs / 7.7 kg
Digital Interface	Yes	Yes
PC Operation	Opto-isolated COM Port for Windows OS	Opto-isolated COM Port for Windows OS
Software	GV10x Remote Control	GV10x Remote Control
	100-230 VAC 50/60 Hz, 13.56 MHz RF	100-230 VAC 50/60 Hz, 13.56 MHz RF
Power Supply	Power consumption 500VA, Impedance 50 Ohms	Power consumption 500VA, Impedance 50 Ohms



Stainless Steel Chamber

Gentle Asher A04 Chamber	
	1/8" N <sub>2</sub> vent
	Down to 70 mTorr
	Up to 3 TEM Holders
	3-Position toggle (Pump-Off-Vent)
	S/S 8" Ø chamber

PN#	GV/GA
P5C	Patented plasma Source & 1 ea. Spooler Variable Constriction, 0.5 µm inlet gas filter Controller & Cable bundle, MicroPirani Interactive GUI & Software
GA	Gentle Asher A04 Chamber

Pump (Optional)	
IDP3	Idp3 Dry Scroll Pump & Foreline – [120v or 240v]

TEM Holder Sleeves (Optional)	
TEM J	JEOL TEM Holder Sleeve & Plug
TEM F	FEI TEM Holder Sleeve & Plug
TEM H	Hitachi TEM Holder Sleeve & Plug

<sup>1</sup>GV10x DS Asher comprised of a patented Plasma Source and Controller  
Contact ibss Group for hydrogen cleaning

Prices: FOB Burlingame, CA  
Terms: Net 30 Days  
Delivery: 8 weeks ARO  
Warranty: Two Year Limited



## Mobile Cubic Asher (MCA)



1/8" N <sub>2</sub> vent
Up to 99 Watts at 13.56 MHz
Down to 70 mTorr
Shutoff leakage - 1E-8 Torr l/s, 1.3E-9 Pa-m <sup>3</sup> /s
Opto-isolated COM port for Windows OS
Up to 3 TEM Holders
3-Position toggle (Pump-Off-Vent)
7" Touchscreen Control Panel
Qwk-Switch™ Source mounting to transfer to SEM
100-230 VAC, 50/60 Hz, Power consumption 500VA at 50 Ohms
36 x 102 x 51 cm / 40" x 20" x 14" ( HxWxD)
6.5" x 6.5" Al chamber w/ Viewport
Weight 120lbs / 55 kg

### GV10x Remote Control software v1.7

Recipes for multi-users – 10 roll around recipes stored  
 Pressure Trigger – enables plasma ignition at selectable pressure  
 Set and monitor – cleaning Power & Duration

PN#	Mobile Cubic Asher
MCA	Mobile Cubic Asher: <ul style="list-style-type: none"> <li>• Chamber</li> <li>• GV10x Qwk-Switch™ DS <sup>1</sup>Source</li> <li>• Controller</li> <li>• ibss Software</li> <li>• 60 l/m Scroll Pump w/ Shutoff Valve &amp; MicroPirani</li> </ul>
TEM Holder Sleeves	
TEM J	JEOL TEM Holder Sleeve & Plug
TEM F	FEI TEM Holder Sleeve & Plug
TEM H	Hitachi TEM Holder Sleeve & Plug
Optional SEM Cleaning Items	
QS4T	Qwk-Switch Adapter & Plug – One per SEM
SP	<sup>2</sup> Spooler for SEM chamber cleaning – One per SEM to be cleaned
GCR	500 psi Gas Cylinder & Regulator 14.25" x 3.53" Plasma Driving gas

<sup>1</sup>GV10x DS Asher comprised of a patented Plasma Source and Controller

<sup>2</sup> Identify SEM[s] port dimension to select correct spooler

Contact ibss Group for hydrogen cleaning

Prices: FOB Burlingame, CA  
 Terms: Net 30 Days  
 Delivery: 6 weeks ARO  
 Warranty: Three Year Limited



## Chiario



Touchscreen Control Panel

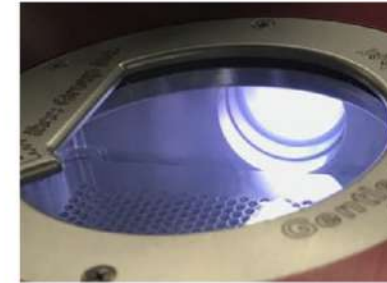

UV Protected Viewport

GV10x w/ Qwk-Switch™ fitting for quick shift to SEM <sup>1</sup>
7"x7" chamber w/ 3 TEM holder ports & swing away viewport
Up to 99 Watts at 13.56 MHz RF
80 l/s turbo pump (1E <sup>-6</sup> Torr base pressure)
Shutoff leakage - 1E <sup>-8</sup> Torr l/s, 1.3E-9 Pa-m <sup>3</sup> /s
Opto-isolated for SEM protection
7" Touchscreen Panel – Set Power(w), Cleaning Duration, Pressure Trigger
Sequenced ON/Off/Vent toggle
1/8" N <sub>2</sub> vent
100-230 VAC, 50/60 Hz, Power consumption 500VA at 50 Ω
H x W x D: 36 x 102 x 51 cm / 40" x 20" x 14"
Weight: 120 lbs./55 kg

### Remote Control software for PC

- Set Power(W) & Time
- Set min/max power limit
- Pressure Trigger
- Recipes
- Logging
- Online Support

PN#	Description
CHV	CHIARIO™
Optional Accessories	
TEM J	JEOL TEM Holder Sleeve & Plug
TEM F	FEI TEM Holder Sleeve & Plug
TEM H	Hitachi TEM Holder Sleeve & Plug
OM	Stereo Microscope 104 mm WD, 0.7x mag w/ LED illumination
GCR	58L Cylinder & Regulator (Gasco UN1954) Recomendad Gas Mixtures: N <sub>2</sub> /H <sub>2</sub> , O <sub>2</sub> /Ar or He/H <sub>2</sub>

<sup>1</sup>GV10x DS Asher comprised of a patented Plasma Source and Controller  
 Contact ibss Group for hydrogen cleaning

Prices: FOB Burlingame, CA  
 Terms: Net 30 Days  
 Delivery: 8 weeks ARO  
 Warranty: Two Year Limited



# GV10x 2UAD Controller

4" Touch Screen / Bright Display / User Friendly Interface

2U rackmount controller allows the user to easily navigate between control menu and set-up menu. Navigate to the operating menu to setup power limit, ignition time and power, and automate your plasma cleaning process with pressure trigger. Return to the control menu to set your desired operating power (W) and duration. Easily know when your cleaning is done with color indicator and progress bar.



*"Quantitative results for optimum cleaning rates."*

*"Cleaning rates were so high that depositions were removed faster than expected..."*

- Cells Alba Synchrotron  
Light Facility

*"The ibss GV10x cleaner was fast, simple to use and did not require any modifications to the vacuum system."*

- CARL ZEISS SMT

*"GV10x results were so dramatic that our report sounds like an advertisement"*

- Hitachi

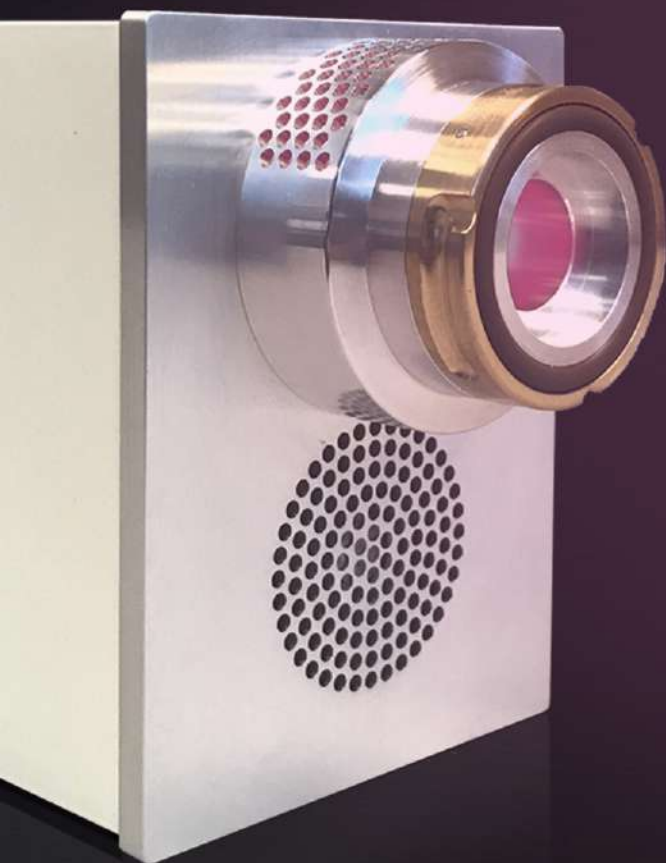

*GV10x Plasma Asher  
Solution to chamber contamination.*

