

EPS Series

120/200W DC OUTPUT UPS

GENERAL CHARACTERISTICS:

Uninterruptible power supply for 48V batteries

3-state battery charging

Configurable load parameters

Alarm signaling using potential-free relays

Ethernet port for remote configuration and monitoring

Integrated web server and SNMP

Battery test without heat dissipation

Battery connection via solid-state relay

Isolation input-output of 10kVac

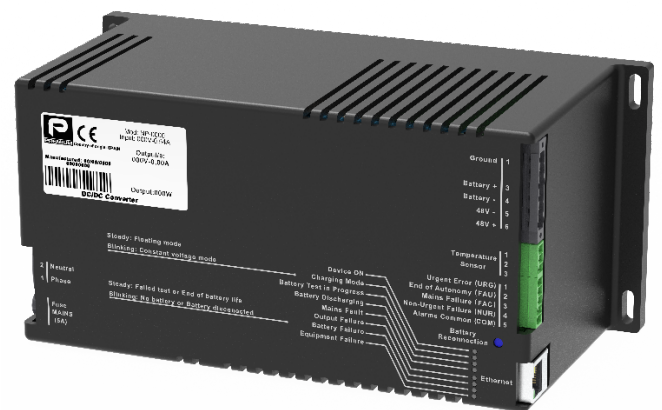

3 YEAR
WARRANTY
INDUSTRY

 **ROHS**
REACH

Product Reference	Rated input AC voltage	Rated output voltage	Maximum output power	Maximum output current	Maximum peak current
EPS-120-5192	230Vac	48V	120W	3.1A	4.6A 10s
EPS-200-5193	230Vac	48V	200W	5.2A	10.3A 10s



INPUT	
Rated input voltage	230Vac
Input voltage range	184 ... 264Vac
Mains frequency range	47 ... 63Hz
Inrush current	See table 1
Power factor	>0.6
OUTPUT	
Rated output voltage	48V
Output voltage range	39 ... 60V
Maximum current	See table 1
Maximum peak current (10s per minute)	See table 1
Total output power	See table 1
Total peak output power	See table 1
Line regulation	<0.1%
Ripple	< 50mVpp
Noise (BW 20MHz)	< 100mVpp
BATTERY	
Charging method	Constant current / Absorption / Float
Battery type	Lead-acid, 48V
Battery capacity	EPS-120: 1Ah-15Ah EPS-200: 10Ah-38Ah
Maximum charging current (configurable)	See table 1
Standby battery self-consumption	<0.25mA
Battery test	By measure of capacity discharged on the load
ENVIRONMENTAL	
Storage temperature	-25 ... 70°C
Operating temperature	-10 ... 60°C
Maximum relative humidity	95% non-condensing
Refrigeration	By natural convection
Environmental requirements	RoHS according to Directive 2011/65/EU and REACH
Mechanical and temperature tests	See Table 2
EMC	
Emissions	See Table 3
Immunity	See Table 4
SAFETY	
Electrical safety	IEC62368-1
Dielectric strength:	
• Input / Output, Signals, Ground	10kVac 50Hz 1 min.
• Output, Signals / Ground	2.5kVac 50Hz 1 min
• Alarms, Ethernet /Ground	1kVac 50Hz 1 min
MECHANICAL	
Size	247 x 115 x 115 mm
Weight	1.3 kg
CONTROL	
Battery reconnect button	Allows you to start the charger in the absence of mains voltage
LEDs	<ul style="list-style-type: none">• Charger ON• Charging state (fast charging or float)• Running battery Test• Battery discharge• Mains Power Failure• Output Error• Battery Error• Charger Error
Urgent failure alarm	Contact closed in case of alarm: <ul style="list-style-type: none">• Battery failure• Internal charger failures• Failures involving battery disconnection or charging



End of Autonomy Alarm	Contact closed in case of alarm: <ul style="list-style-type: none"> The battery has reached the minimum voltage value (it is activated for a while before the battery is disconnected)
Mains Failure Alarm	Contact closed in case of alarm: <ul style="list-style-type: none"> Input voltage out of range No tension at the entrance
Alarm Non-urgent failure	Contact closed in case of alarm: <ul style="list-style-type: none"> Battery voltage above its maximum value Output voltage out of range Temperature probe error Battery temperature out of range
Alarm Specification (Urgent Failure):	
Type	Electromechanical relay
Maximum voltage	220V
Maximum current	8A
Alarm Specification (Other Alarms):	
Type	Solid State Relay
Maximum voltage	200V
Maximum current	0.2A
PROTECTIONS	
Overcurrent in loads	Electronic current limitation
Deep battery discharge	Battery disconnection
Battery overcurrent	Self-resetable fuse
Overcurrent at the entrance	Fuse

ORDERING CODES

Code	Mains input		Output voltage			Output current Max.		Output power Max		Charging Current	
	voltage range [Vac]	Inrush current [A]	Nominal [Vdc]	Float [Vdc]	Minimum [Vdc]	Cont. [A]	Peak 10s [A]	Cont. [W]	Peak 10s [W]	Nom. [A]	Max. [A]
EPS-120-5192	184 ... 264	12	48.0	54.24*	39.0*	3.1	4.6	120	180	0.25*	3
EPS-200-5193	184 ... 264	20	48.0	54.24*	39.0*	5.2	10.3	200	400	1.30*	5

(*) Factory defaults



BLOCK DIAGRAM

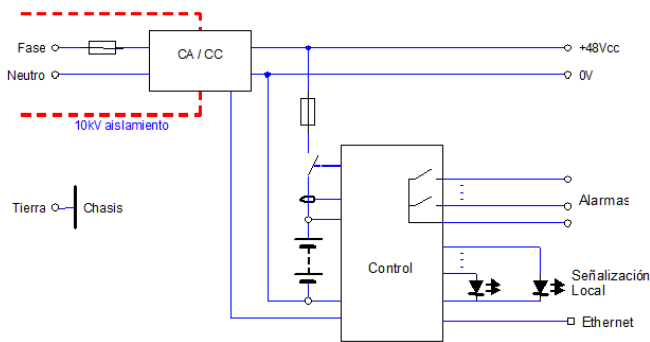

CONNECTIONS

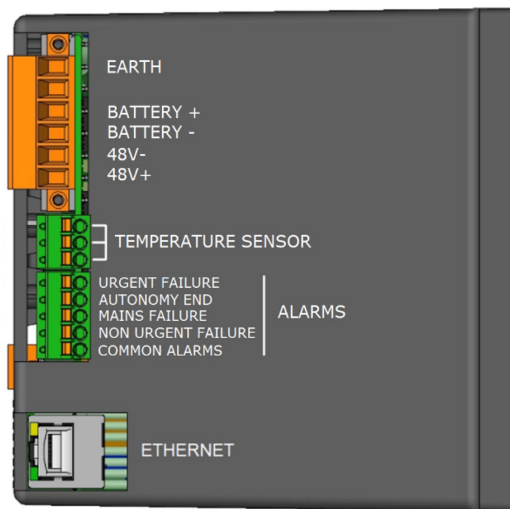

Right side view

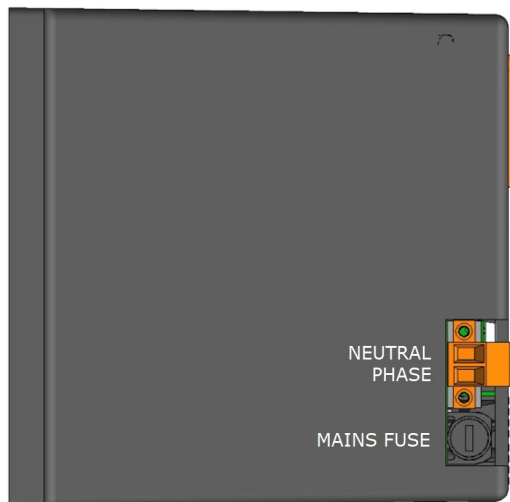

Left side view

DESCRIPTION

The equipment consists of a rectifier-charger that, in case of having input AC voltage, provides a regulated output voltage and charges the battery in a controlled way.

The equipment comprises a switched power supply and a three-state battery charger. It also incorporates alarm circuits that signal failures in the input voltage, in the battery or in the charger. Alarm outputs are potential-free relay contacts.

Mains supply operation

In normal operation, the equipment provides the output current and at the same time charges the battery in a controlled way until it is brought to the floating state. The maximum charging current, as well as the rest of the parameters related to battery charging, are configurable by the user through the Ethernet connection of the equipment. In case the sum of the charging current and the output current exceeds the maximum current of the equipment, the output power is prioritized.

The equipment allows, with battery support, to provide current peaks above the maximum temporarily.

The average of this extra current provided by the battery should not be higher than the average of the charging current since, if so, the battery would end up discharging.

If the equipment is not able to provide output voltage, either due to a failure in the input AC voltage or due to the failure of the charger, the corresponding alarm will be activated.

Operation without input AC voltage

In the absence of mains voltage, the battery feeds the output and the charger control. The output voltage will then depend on the discharge curve of the battery.

If the battery is discharged below a certain level (configurable), the end of autonomy alarm will be activated and, after a certain time, it will be permanently disconnected from the charger to prevent a situation of deep discharge that could damage it. Once the mains voltage is reset, charging starts again.

Battery test

The charger has a system that periodically and automatically checks the status of the batteries. Starting from the float state, the load connected to the output is used to discharge the battery down to 40%. If the battery is able to maintain the voltage above a certain threshold until it reaches the required depth of discharge, the test is considered successful. Since the discharge current depends on the load connected to the equipment (and is not so much controllable), the duration of the battery test is limited. If after the time limit it has not been possible to discharge the battery to the required level, the test is considered correct as well. The test parameters (time between tests, maximum test duration, depth of discharge and/or threshold voltage) are configurable by the user.

Battery temperature sensor

The equipment includes a temperature sensor that can be attached to the battery. If used, the fast charging and flotation voltages will be optimally adjusted depending on the temperature of the battery. In this way it is possible to preserve the useful life of the battery.



ETHERNET PORT

The configuration and monitoring of the status of the equipment is carried out through the Ethernet port. The system has the following characteristics:

- IPv4 support
- M2M communication based on SNMP protocol to configure, query and update the equipment.
- User authentication through user and Web pass
- User authentication using LDAP
- Consultation/modification of firmware, alarms and configuration via remote from Web interface
- DHCP Dynamic Host Configuration Protocol
- Clock synchronization using SNTP protocol

In addition to the features indicated, the system has a function that allows the computer to start with a specific fixed IP address, through the button (Battery reconnection) placed on the front panel.

INSTALLATION

Perform the installation of the equipment following the connection drawings. The value of the charging current can be changed from the default value via the Ethernet connection.

For security reasons it is required:

Make it accessible and easy to disconnect the equipment from the mains.

In case of replacement of input fuse or battery, make sure to use one of the same characteristics and perform the installation with the equipment disconnected from the mains.

Perform the installation of the equipment in a safe environment in accordance with current regulations and electrical safety directives.

Use a mains connection cable with a minimum section of 0.75mm².

CHARGING CHARACTERISTIC

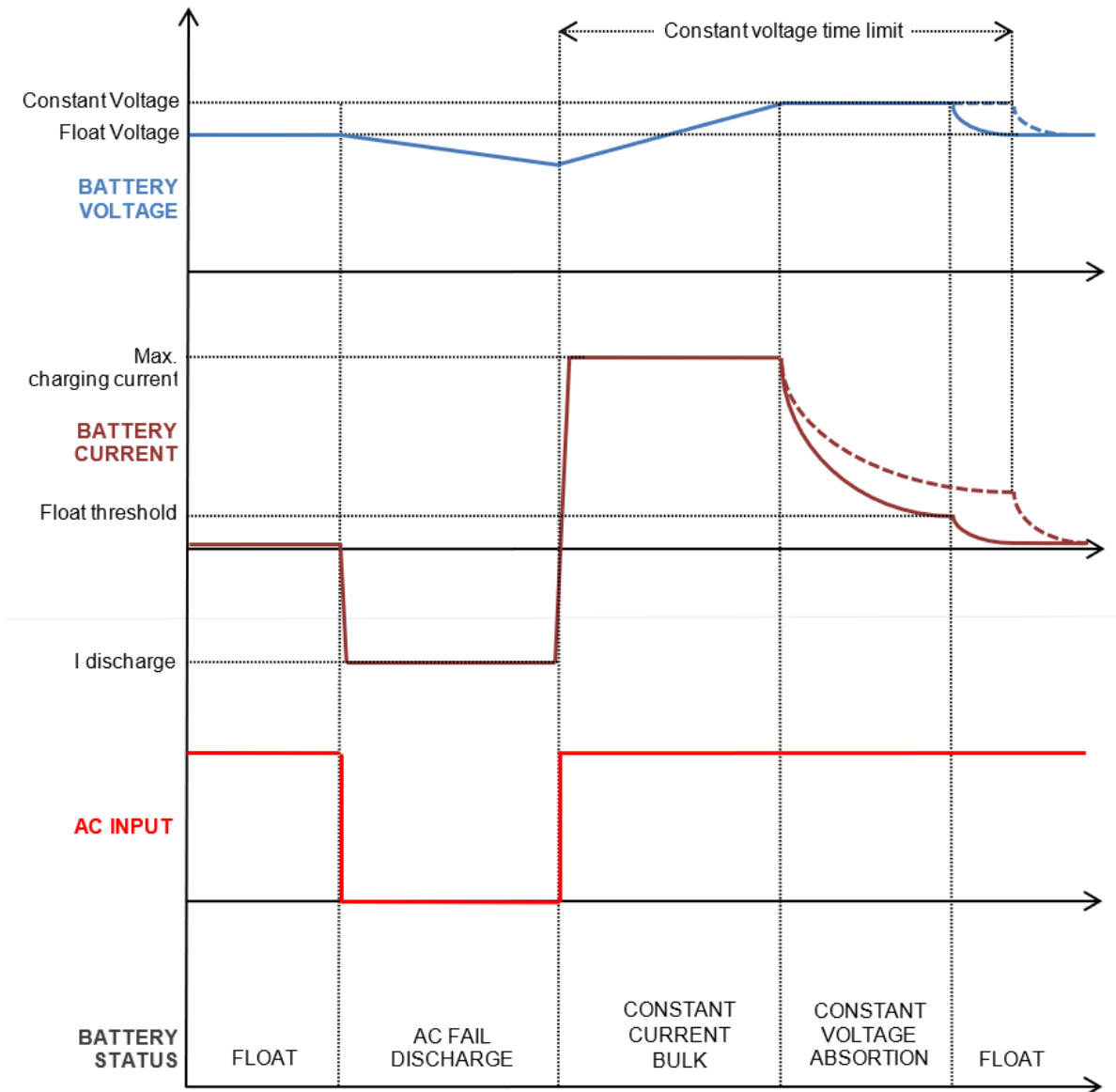



DIMENSIONS

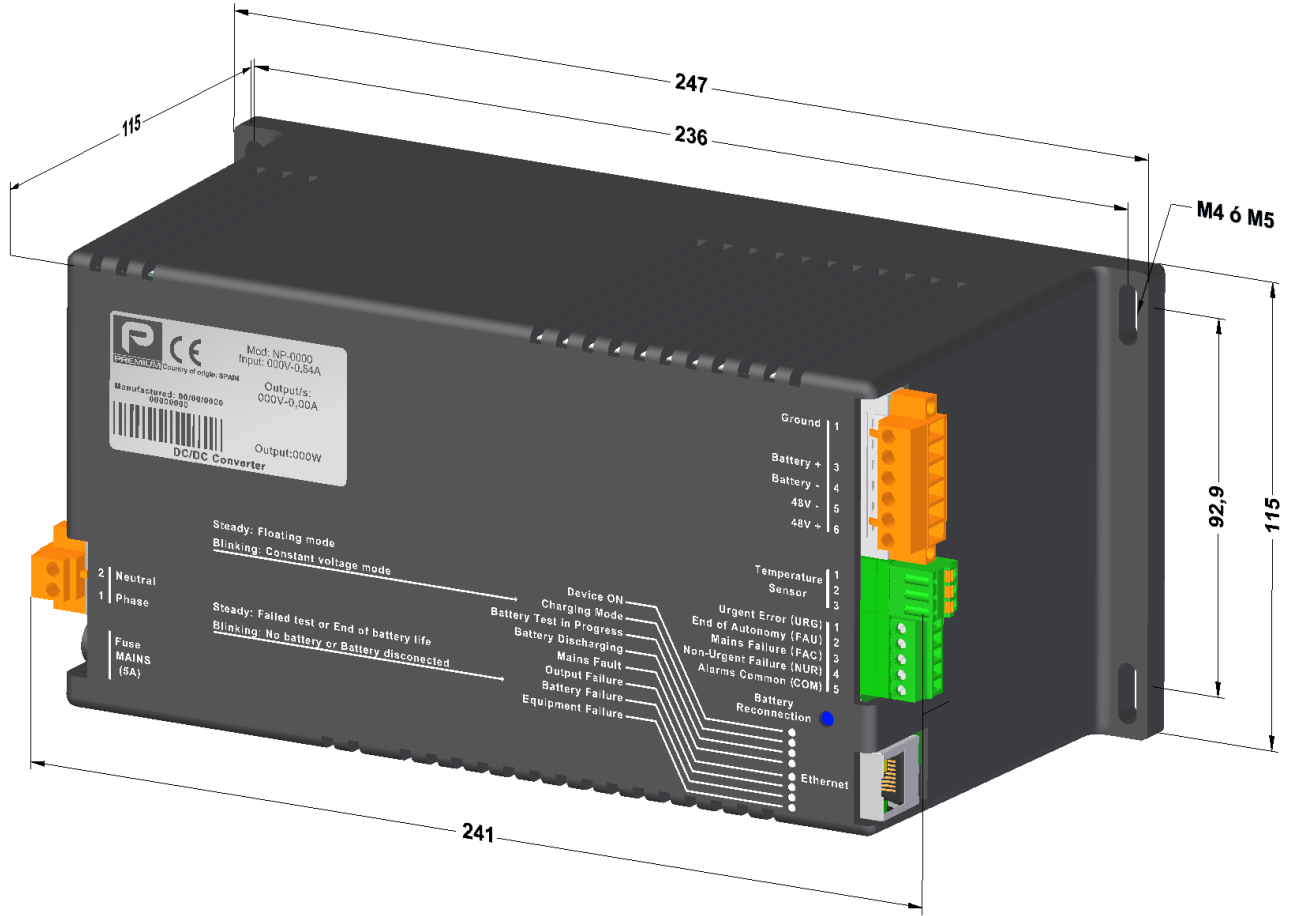

Dimensions in mm.



Table 2 -Mechanical and temperature tests

Trials	Levels to apply:	Conditions	Acceptance criteria
Humid heat	Temperature: 40° C. Humidity: 93%. Duration of the test: 4 days (accelerated aging).	Equipment connected	Criterion A
Dry heat	Type of test: To be defined at the time of the test Temperature: 60° C. Duration of the test: 16 hours.	Equipment connected	Criterion A
Temperature variation	Cold temperature: -10° C. Hot temperature: 60° C. Transition time: 2 minutes. 5 cycles of 3h each	Equipment disconnected	Criterion A
Vibration	According to UNE EN 60 870-2-2 Table 3 Class Bm. Frequency range and severity: From 2Hz to 9 Hz: constant displacement = 3mm (peak). From 9Hz to 200Hz: constant acceleration = 10m/s ² . From 200Hz to 500Hz: constant acceleration = 15m/s ² . Test direction: On all 3 axes.	Equipment connected	Criterion A
	According to ETSI EN 300 019-2-2 Public Transportation: Environmental Class 2.3 Random	Equipment disconnected, installed in cabinet and packed for shipment	Criterion B
Drop	According to ETSI EN 300 019-2-2 Public Transportation: Environmental Class 2.3 (Characteristic severity; <20kg)	Equipment disconnected, installed in cabinet and packed for shipment	Criterion B



Table 3 - EMC: Emissions

TEST	PORT	REGULATIONS
Radiated emissions	Surrounding	EN 55032 class B. Measurements made at 3m between antenna and equipment with boundary conversion
Conducted emissions	48V power terminals	EN 55032 Class A
	Alternating input power terminals	EN 55032 Class B

Tabla 4 - EMC: Inmunidad

TEST	NORMA	PUERTO	STRICTDAD	CONDITIONS	CRY.
Magnetic field	IEC61000-4-8	Surrounding	100A/m	50/60Hz 1minute	A
		Surrounding	1000A/m	50/60Hz 1... 3s	A
Radiated high-frequency	IEC61000-4-3	Surrounding	30V/m	80M - 1GHz M. 80% 1kHz	A
Conducted RF	IEC61000-4-6	Input	10V	0.15-80MHz M. 80% 1kHz	A
		Output	10V	0.15-80MHz M. 80% 1kHz	A
		Signal	10V	0.15-80MHz M. 80% 1kHz	A
Electrostatic discharge	IEC61000-4-2	Case	±15kV	Air	A
		Case	±8kV	Contact	A
Fast transients	IEC61000-4-4	AC Input	±4kV	Tr/Th: 5/50 ns	B
		Output	±500V	Tr/Th: 5/50 ns	B
		Signal	±2kV	Tr/Th: 5/50 ns	B
Surges	IEC61000-4-5	AC Input diff.	±2kV	Tr/Th: 1.2/50µs	B
		AC Input comm.	±4kV	Tr/Th: 1.2/50µs	B
		Output diff	-	-	B
		Output comm.	±500V	Tr/Th: 1.2/50µs	B
		Signals diff	±1kV	Tr/Th: 1.2/50µs	B
		Signals comm.	±2kV	Tr/Th: 1.2/50µs	B
Magnetic field	IEC61000-4-10	Surrounding	100Am		A
Voltage DIPS/SAGS	IEC61000-4-11	AC Input	70%	10ms (zero crossing)	B
		AC Input	40%	0.1s (zero crossing)	B
		AC Input	5%	5s (zero crossing)	B
		AC Input	0%	4s (zero crossing)	B
Ring wave	IEC61000-4-12	AC Input	2kV Between the lines 4kV Ground Line		A
		Output and signals	2kV Between the lines 4kV Ground Line		A
Harmonics	IEC61000-4-13	AC Input	Class 2		A



Insulation tests

Method

Equipment disconnected from power, grounded, with the terminals of each group short-circuited together.

I/O groups formed:

- AC power terminals.
- DC power terminals.
- Ethernet and Alarms.

Insulation resistance

> 100Mohm with $\pm 500\text{Vdc}$ between each group and ground. Reading performed 5 seconds after applying voltage.

Note: The test is performed at the beginning and end of all isolation measures. The difference between the two measures is <20%.

Dielectric stiffness

The voltage is applied for 1 minute without producing any disruptive discharge or a change in the insulation resistance.

- AC power terminal = 10kVac / 50Hz between active parts and GND (*) and 10 lightning pulses ($\pm 20\text{kV}$ 1.2/50 μs)
- DC power terminals = 2.5kVca / 50Hz and 10 lightning pulses (5kV 1.2/50 μs) 5 at each polarity.
- Ethernet terminals and alarms = 1kVca / 50Hz and 10 lightning type pulses (2kV 1.2/50 μs) 5 in each polarity.

(*) GND is considered to be a metallic sheet covering totally the outer part of the equipment connected to the metallic parts of the enclosure.

Isolation to voltage impulses

- ± 5 kV in Common Mode. Between each group and ground, with all other groups joined in short circuit (except Ethernet port and Alarms that support ± 2 kV).
- ± 1 kV in Differential Mode between the terminals of each group.



EU, UKCA DECLARATION OF CONFORMITY

El abajo firmante, en representación de la siguiente:

Fabricante: PREMIUM, S. A.,
Dirección: C/ Dolors Aleu 19-21, 08908 L'Hospitalet de Llobregat, ESPAÑA

Por la presente declara que el producto:

Tipo: SAI de CC
Modelos: **EPS-120-5192, EPS-200-5193**

es conforme con las disposiciones de la(s) siguiente(s) directiva(s) de la UE:

35/2014/UE SI 2016 No 1101	Baja tensión / Las regulaciones de equipos eléctricos (seguridad)
30/2014/UE SI 2016 No 1091	EMC / Normativa de compatibilidad electromagnética
2015/863/UE SI 2012 No. 3032	RoHS / Restricción del uso de ciertas sustancias peligrosas en equipos eléctricos y electrónicos

y que se han aplicado normas y/o especificaciones técnicas a las que se hace referencia en la parte superior:

EN 62368-1: 2014	Seguridad. Equipo de audio/vídeo, tecnología de la información y las comunicaciones
Véase tabla 3	Emisión
Véase tabla 3	Inmunidad

Año de marcado CE: **2020**; Año de marca UKCA: **2021**

Notas:

Para el cumplimiento de esta declaración el producto debe ser utilizado únicamente para el fin que ha sido concebido, considerando las limitaciones establecidas en el manual de instrucciones y en la ficha técnica.

L'Hospitalet de Llobregat, 31-05-2021

Miguel Angel Fernandez
Chief Research & Development Officer

PREMIUM S.A. is an ISO9001 and ISO14001
certified company by **Bureau Veritas**